

Ersatzteilliste

(1.280-140.2) KM 105

KM 105 (1.280-140.2)	4
60 Hochentleerung KM 105/110 R D	5
10 Rumpfgeraet Verbrenner KM 105_1xx	6
ETL Rumpfgeraet Verbrenner KM 105/1xx (5.972-220.0)	7
10 Rahmen Motor KM 105_1xx	9
37 Set Bremse KM Medium Range (2.643-134.0)	12
20 Kehrwalzenkasten Verbrenner KM 105_1xx	13
14 Sterngriff (5.322-060.0)	16
30 Lenkung Verbrenner KM 105_1xx	18
3 Radgabel kpl. Benzin (4.058-349.0)	21
9 Lagerung Vorderrad kpl. (4.058-353.0)	23
60 Lagerbock kpl. (4.251-054.0)	25
22 Lenksaeule kpl. (4.058-352.0)	27
40 Pedal kpl. Verbrenner	29
1 Pedal Guss Verbrenner (2.852-199.0)	31
40 Pedal Guss Verbrenner (2.852-199.0)	33
50 Haube rechts Verbrenner	35
12 Halter Handbremse Ersatz (2.643-753.0)	37
80 Oeltank Hydraulik KM 1xx_1xx	39
90 Frontteil KM 105_1xx	41
20 Elektronik Verbrenner KM 1xx_1xx	43
10 ETL Elektronik Verbrenner KM 1xx/1xx (5.972-237.0)	44
40 Starter Generator 60 A	46
ETL Starter Generator 60 A - KM Medium (5.972-240.0)	47
50 Kabelsatz Diesel kpl. KM 105/110 R D	49
ETL Kabelsatz Diesel KM 105/110 (5.972-304.0)	50
1 Kabelsatz Diesel KM 105/110 R D	52
60 Rumpfgeraet Hochentleerung KM 105_110	54
ETL Rumpfgeraet Hochentleerung KM 105/11 (5.972-223.0)	55
10 Hochentleerung KM 105_110	57
33 Reedsensor 650 mm (6.632-541.0)	60
10 Steckergehaeuse 2-Wege Superseal 1.5 (6.422-055.0)	61
20 Filterkasten APFC KM 105_110	62
30 Bedienfeld Verbrenner KM 105_110 (2.851-420.0)	65
14 Set Schluessel gelb KIK KM (4.035-542.0)	67
40 Steuerblock (6.413-555.0)	69
60 Set Taster (2.643-954.0)	70
70 Set Schluessel gelb KIK KM (4.035-542.0)	72

Inhaltsverzeichnis

70 Hydraulikkreis KM 105/110	74
ETL Hydraulikkreis KM 105/110 (5.972-230.0)	75
80 Antrieb Motor Diesel KM 105_1xx	77
ETL Antrieb Diesel KM 105/1xx (5.972-218.0)	78
2 Zahnradpumpe hydraulisch 2,6 ccm (6.503-037.0)	82
50 Oel Ablass KM 105/1xx R D (4.423-045.0)	83
62 Dieselmotor Yanmar L70N (6.491-007.0)	85
91 Umbau Set 6 PK 1270mm (2.643-445.0)	87
90 Haube links Diesel KM 105_1xx	90
ETL Haube links Diesel KM 105/1xx (5.972-222.0)	91
3 Set Federblech Reedkontakt (2.643-844.0)	93
20 Reedsensor 650 mm (6.632-541.0)	95
10 Steckergehaeuse 2-Wege Superseal 1.5 (6.422-055.0)	96
200 Seitenbesen rechts + Kehrsichel	97
10 Kehrsichelsystem rechts hydraulisch	98
30 Seitenbesen rechts hydraulisch	99
40 Seitenbesen hinten hydraulisch	102
20 Hydraulikkreis Seitenbesen rechts KM 105	104
30 Hydraulikkreis Kehrsichelsystem KM 105_1	106
290 Sitz Standard kpl.	107
ETL Sitz Standard KM Medium (5.972-234.0)	108
1 Sitz COBO PS48 (6.394-729.0)	110
320 Radsatz Standard Verbrenner	112
ETL Radsatz Standard KM Medium (5.972-231.0)	113

KM 105 (1.280-140.2)

POS	Beschreibung	Anzahl	Einheit
60	Hochentleerung KM 105/110 R D	1.000	ST
200	Seitenbesen rechts + Kehrsichel	1.000	ST
290	Sitz Standard kpl.	1.000	ST
320	Radsatz Standard Verbrenner	1.000	ST

60 Hochentleerung KM 105/110 R D

POS	Beschreibung	Anzahl	Einheit
10	Rumpfgeraet Verbrenner KM 105_1xx	1.000	ST
20	Elektronik Verbrenner KM 1xx_1xx	1.000	ST
30	Dokumentation Verbrenner	1.000	ST
40	Starter Generator 60 A	1.000	ST
50	Kabelsatz Diesel kpl. KM 105/110 R D	1.000	ST
60	Rumpfgeraet Hochentleerung KM 105_110	1.000	ST
70	Hydraulikkreis KM 105/110	1.000	ST
80	Antrieb Motor Diesel KM 105_1xx	1.000	ST
90	Haube links Diesel KM 105_1xx	1.000	ST

10 Rumpfgeraet Verbrenner KM 105_1xx

POS	Artikelnr.	Beschreibung	Anzahl	Einheit
0	5.972-220.0	ETL Rumpfgeraet Verbrenner KM 105/1xx	1.000	ST

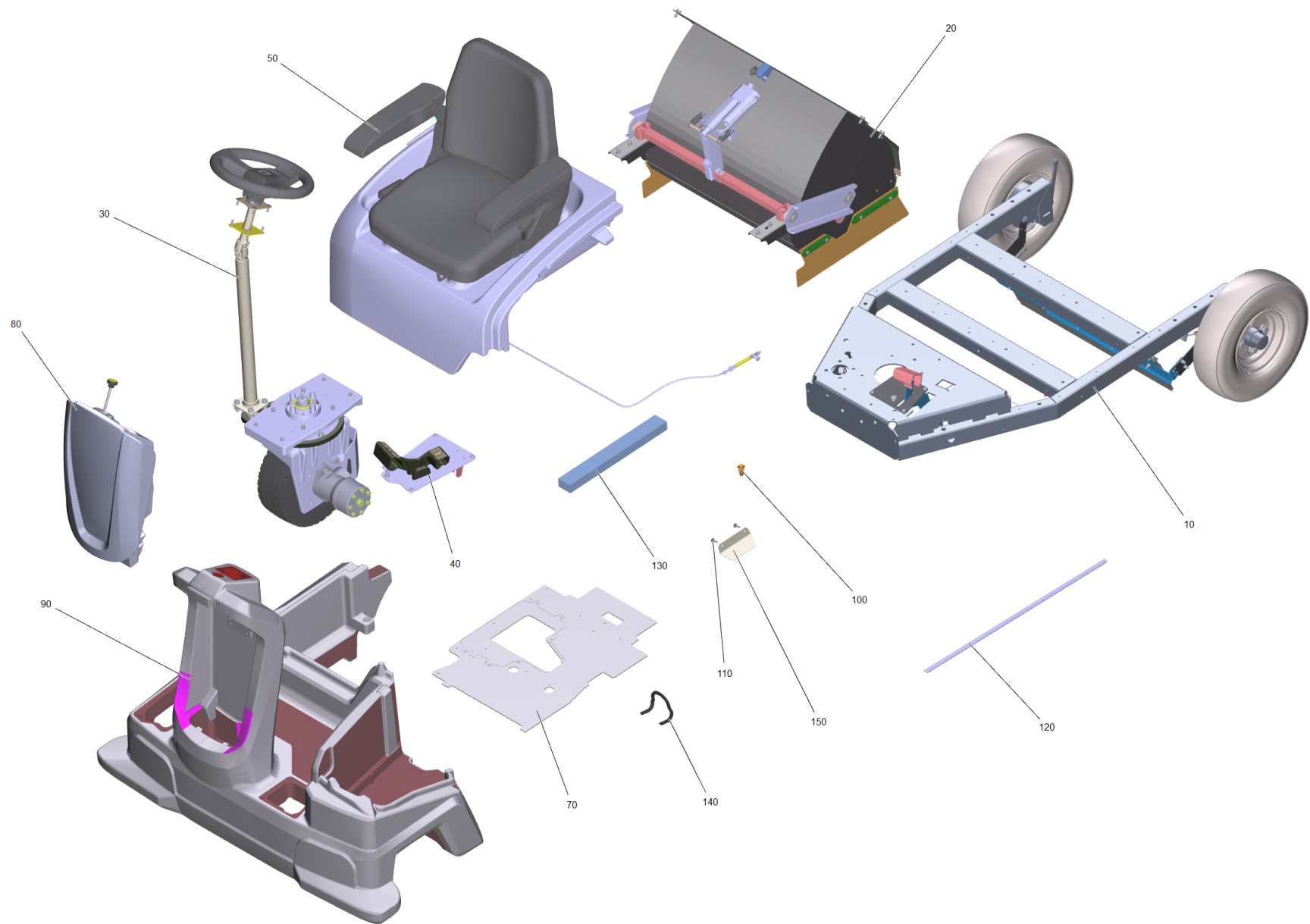

ETL Rumpfgeraet Verbrenner KM 105/1xx (5.972-220.0)

POS	Artikelnr.	Beschreibung	Anzahl	Einheit	Bemerkung	Fußnotentext
10		Rahmen Motor KM 105_1xx	1.000	ST		
20		Kehrwalzenkasten Verbrenner KM 105_1xx	1.000	ST		
30		Lenkung Verbrenner KM 105_1xx	1.000	ST		
40	2.852-199.0	Pedal Guss Verbrenner	1.000	ST	Version 2	
40		Pedal kpl. Verbrenner	1.000	ST	Version 1	
50		Haube rechts Verbrenner	1.000	ST		
70	5.033-883.0	Staubschutz Benzin rechts	1.000	ST		
80		Oeltank Hydraulik KM 1xx_1xx	1.000	ST		
90		Frontteil KM 105_1xx	1.000	ST		
100	6.310-194.0	Spreizniet Kunststoff D5	2.000	ST		
110	6.303-125.0	Schraube 5x20-Sonder In6Rd+Spitze	2.000	ST		
120	6.273-055.0	Profildichtung	1.000	M		ALS METERWARE BESTELLEN
130	6.286-606.0	Dichtung	1.000	ST		
140	6.368-089.0	Kantenschutz	1.000	M		ALS METERWARE BESTELLEN
150	2.643-775.0	Set Blechteil Hitzeschutz	1.000	ST		

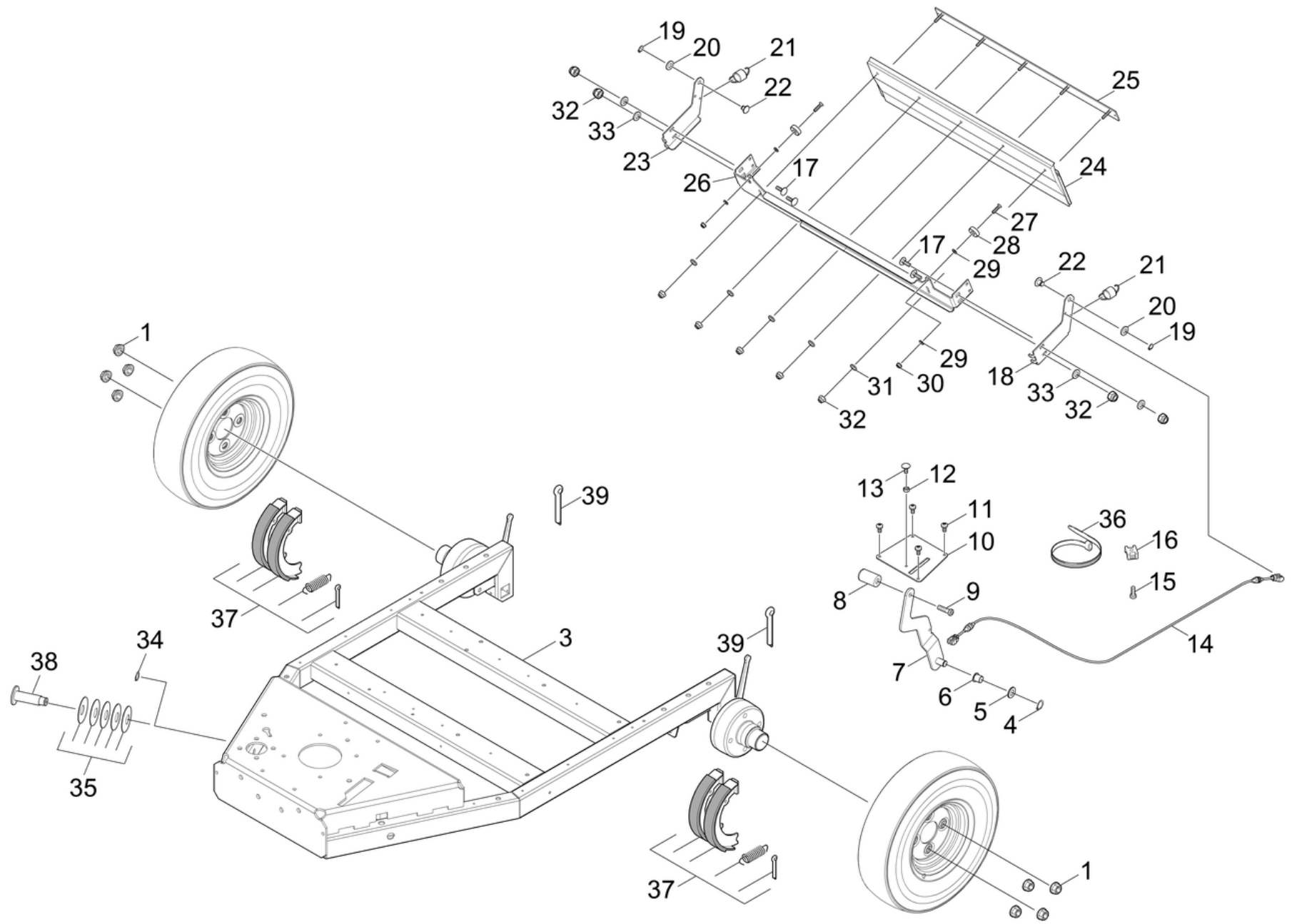

10 Rahmen Motor KM 105_1xx

POS	Artikelnr.	Beschreibung	Anzahl	Einheit
1	7.311-012.0	Radmutter A M12X1,5-8-A2E DIN74361	8.000	ST
3	4.058-419.0	Rahmen Motor Bremse 105/110	1.000	ST
4	7.343-004.0	Sicherungsring 15x1-FST-PHR DIN 471	1.000	ST
5	7.312-028.0	Scheibe 14-200HV-A3E ISO7090	1.000	ST
6	6.403-028.0	Gleitlager	1.000	ST
7	4.058-290.0	Pedal kpl. 105/110	1.000	ST
8	5.321-701.0	Griff	1.000	ST
9	7.306-224.0	Schraube M10x35-A2-70 DIN 7984	1.000	ST
10	5.095-486.0	Blechteil Abdeckung GSK	1.000	ST
11	7.306-089.0	Schraube M6x12 -8.8-R2R (In6Rd)	4.000	ST
12	7.311-093.0	6kt-Mutter M8 -8-R2R ISO 4032	1.000	ST
13	7.303-273.0	Fl.Rd.Schr. M8x25 -St-P2R DIN 603	1.000	ST
14	6.431-295.0	Bowdenzug	1.000	ST
15	7.303-038.0	Schraube M5x12 -St-P2R (In6Rd)	1.000	ST
16	6.648-602.0	Halter	1.000	ST
17	7.303-139.0	Fl.Rd.Schr. M6x20 -A2 DIN 603	4.000	ST
18	5.095-503.0	Blechteil Arm links	1.000	ST
19	7.343-001.0	Sicherungsring 10x1-Rf-St DIN 471	2.000	ST
20	7.312-005.0	Scheibe 10-200HV-A3E ISO 7090	2.000	ST
21	6.330-199.0	Zugfeder	2.000	ST
22	5.317-725.0	Bolzen mit Nut	2.000	ST
23	5.095-504.0	Blechteil Arm rechts	1.000	ST
24	5.394-889.0	Schuerze Front	1.000	ST
25	4.058-291.0	Blechteil Schuerze kpl.	1.000	ST
26	5.095-229.0	Blechteil Halter Schuerze GSK	1.000	ST
27	7.303-223.0	Senkschr. M5x20 -A2-70(IN6RD) ISO7046-2	2.000	ST
28	7.401-149.0	Kugellager 608-2RS -Wälzl.St DIN 625	2.000	ST
29	7.312-052.0	Scheibe 5 -A2 ISO 7089	4.000	ST
30	7.311-421.0	6kt-Mutter M 5-04-A2E ISO 10511	2.000	ST
31	7.312-140.0	Scheibe 6-160HV-A3E ISO 8738	5.000	ST
32	7.311-512.0	6kt-Mutter M 6-8-A2E ISO 7040	9.000	ST
33	7.312-003.0	Scheibe 6 -200HV-A3E ISO 7090	4.000	ST
34	7.343-015.0	Sicherungsring 15x1-FST-RF DIN 471	1.000	ST

10 Rahmen Motor KM 105_1xx

POS	Artikelnr.	Beschreibung	Anzahl	Einheit
35	6.333-018.0	Tellerfeder 50x22,4x2	8.000	ST
36	6.647-081.0	Kabelband	1.000	ST
37	2.643-134.0	Set Bremse KM Medium Range	1.000	ST
38	5.111-364.0	Bolzen Feder	1.000	ST
39	7.316-345.0	Splint 3,2x32-St-A2E ISO 1234	2.000	ST

37 Set Bremse KM Medium Range (2.643-134.0)

POS	Artikelnr.	Beschreibung	Anzahl	Einheit
20	7.316-347.0	Splint 3,2x25-St-A2E ISO 1234	1.000	ST

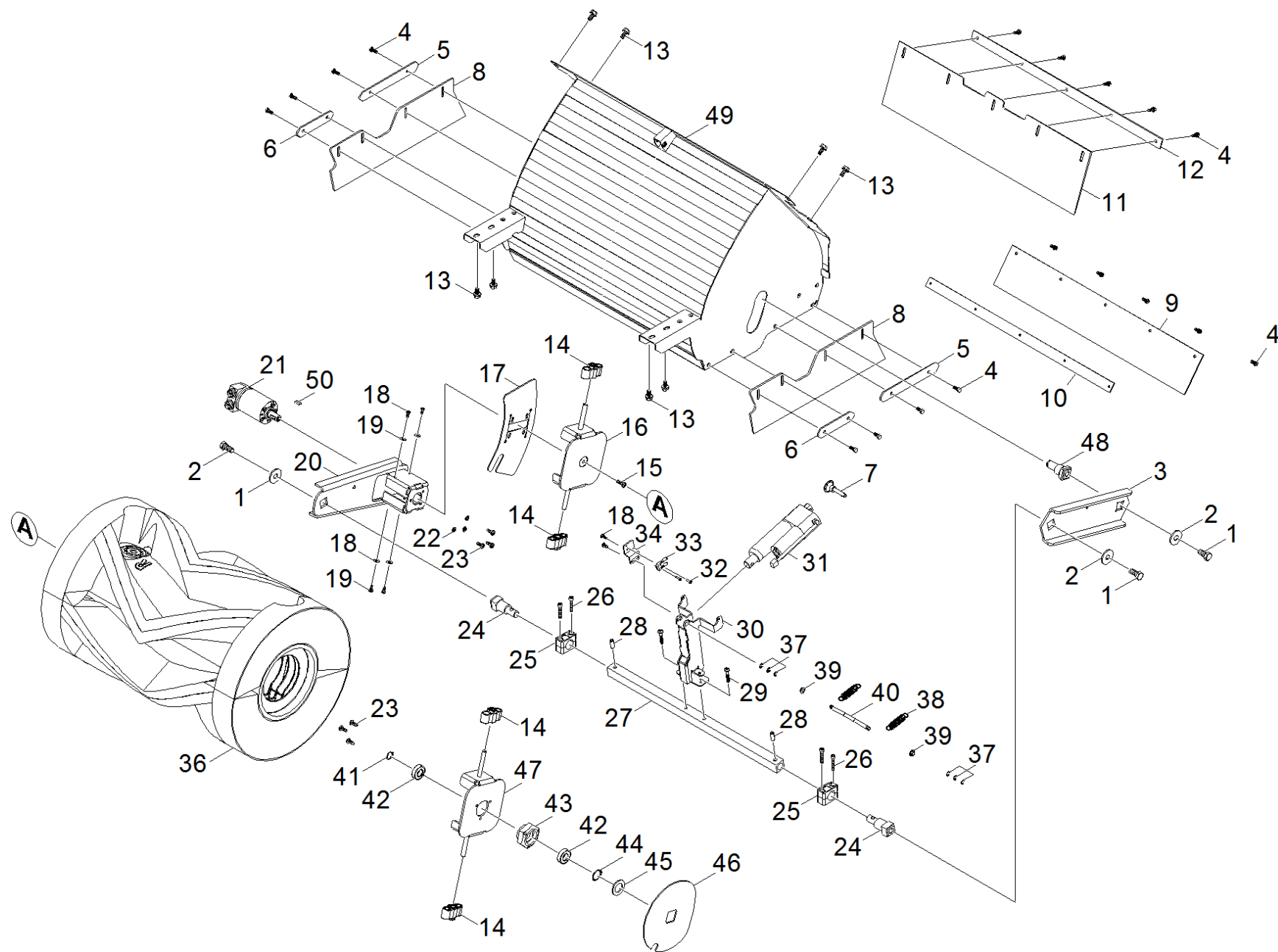

20 Kehrwalzenkasten Verbrenner KM 105_1xx

POS	Artikelnr.	Beschreibung	Anzahl	Einheit
1	7.304-433.0	6kt-Schraube M12x25-8.8-A3E ISO 4017	3.000	ST
2	7.312-287.0	Scheibe 12-200HV-A2E ISO7093-1	3.000	ST
3	5.095-241.0	Blechteil Schwinge links	1.000	ST
4	7.304-158.0	6kt-Schr. M6x15 -PA6.6natur DIN 933	13.000	ST
5	5.095-222.0	Leiste Dichtlippe gross	2.000	ST
6	5.095-223.0	Leiste Dichtlippe klein	2.000	ST
7	6.317-004.0	Steckbolzen mit Arretierung 8x30	1.000	ST
8	5.394-888.0	Schuerze Kehrwalzenkasten seitlich	2.000	ST
9	5.394-887.0	Schuerze Kehrwalzenkasten doppelt	1.000	ST
10	5.095-225.0	Leiste Dichtlippe hinten	1.000	ST
11	5.394-886.0	Schuerze Kehrwalzenkasten hinten	1.000	ST
12	5.095-224.0	Leiste Dichtlippe hinten	1.000	ST
13	7.304-051.0	6kt-Schraube M 8x16-8.8-P2R EN 1665	8.000	ST
14	5.322-060.0	Sterngriff	4.000	ST
15	7.306-092.0	Schraube M6x20-ST- 8.8-R3R (In6RD)	1.000	ST
16	4.058-295.0	Mitnehmer Kehrwalze kpl. re	1.000	ST
17	5.394-917.0	Dichtung Kehrwalzenkasten rechts	1.000	ST
18	7.303-038.0	Schraube M5x12 -St-P2R (In6Rd)	6.000	ST
19	7.312-282.0	Scheibe 5 -A2 ISO 7093-1	4.000	ST
20	4.058-294.0	Schwinge rechts kpl.	1.000	ST
21	6.503-084.0	Hydraulikmotor OMM 12,5	1.000	ST
22	7.312-003.0	Scheibe 6 -200HV-A3E ISO 7090	3.000	ST
23	7.303-047.0	Schraube M6x16 -St-R3R (In6Rd)	6.000	ST
24	5.111-386.0	Achse Schwingen	2.000	ST
25	6.401-473.0	Stehlagergehaeuse geteilte Ausfuehrung	2.000	ST
26	7.306-025.0	Zyl.Schr. M 6x35-8.8-A2E ISO4762	4.000	ST
27	5.111-273.0	Welle Verbindung Schwingen KM105-110	1.000	ST
28	7.314-078.0	Spannstift 8x26 -A ISO 8752	2.000	ST
29	7.306-118.0	Schraube M 6x35 -8.8-R3R (In6Rd)	2.000	ST
30	5.095-237.0	Blechteil Verstellung Kehrwalze	1.000	ST
31	6.504-115.0	Hubzylinder Verstellung Kehrwalze	1.000	ST
32	7.306-050.0	Schraube M2,5x10 -8.8-R2R (In6Rd)	2.000	ST
33	6.630-294.0	Mikroschalter	1.000	ST

20 Kehrwalzenkasten Verbrenner KM 105_1xx

POS	Artikelnr.	Beschreibung	Anzahl	Einheit
34	5.095-320.0	Blechteil Halter Mikroschalter	1.000	ST
36	4.762-521.0	Kehrwalze kpl. Standard 620 mm	1.000	ST
37	7.343-201.0	Sicherungsscheibe 6-FST-PHR DIN 6799	6.000	ST
38	6.330-088.0	Zugfeder	2.000	ST
39	6.403-075.0	Gleitlager 8mm	2.000	ST
40	5.111-301.0	Achse Lagerung Elektromotor	1.000	ST
41	7.343-006.0	Sicherungsring 17x1-St-ph DIN 471	1.000	ST
42	7.401-105.0	Kugellager 6003-2RS Wälzl.St DIN 625	2.000	ST
43	5.122-189.0	Flansch Guss	1.000	ST
44	7.343-008.0	Sicherungsring 25x1,2-St-vz DIN 471	1.000	ST
45	5.115-924.0	Scheibe Parallelogramm SM	1.000	ST
46	5.394-918.0	Dichtung Kehrwalzenkasten links	1.000	ST
47	4.058-396.0	Mitnehmer Kehrwalze links	1.000	ST
48	5.111-270.0	Mitnehmer Kehrwalze rechts	1.000	ST
49	4.058-288.0	Kehrwalzenkasten Schweissbaugruppe kpl.	1.000	ST
50	7.318-002.0	Passfeder 5x5x16 -C45R DIN 6885-1	1.000	ST

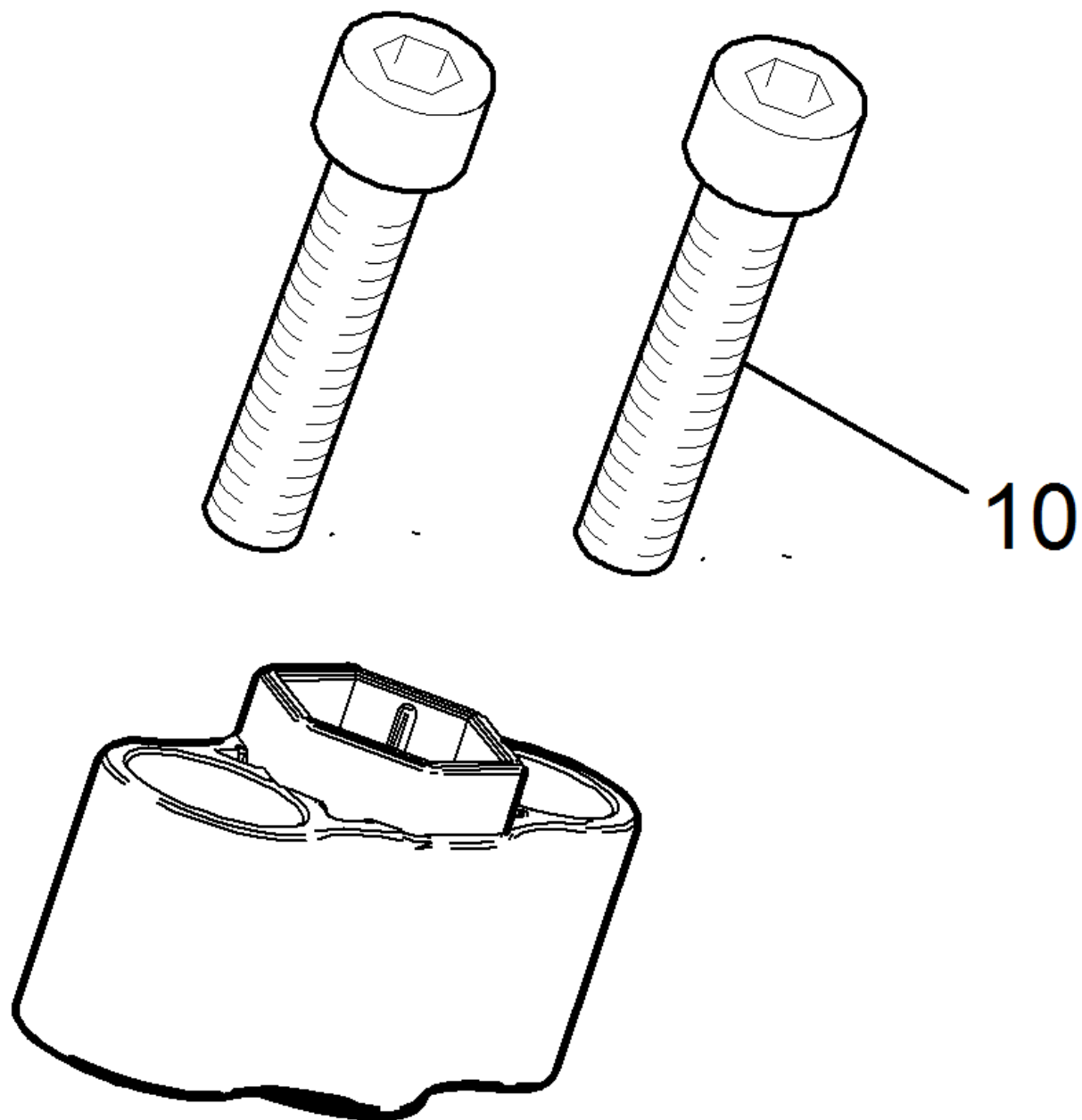

14 Sterngriff (5.322-060.0)

POS	Artikelnr.	Beschreibung	Anzahl	Einheit
10	7.304-031.0	6kt-Schraube M8x55-8.8-A2E ISO 4014	1.000	ST

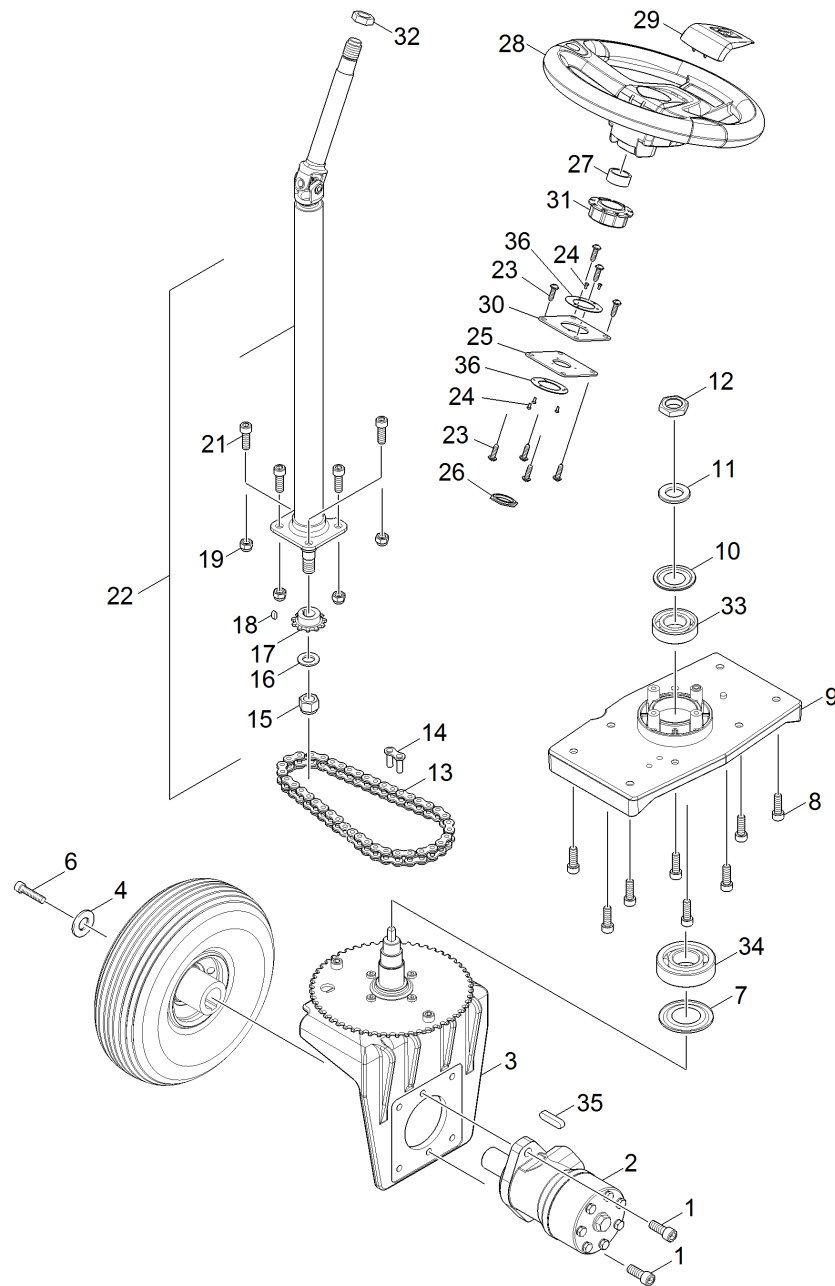

30 Lenkung Verbrenner KM 105_1xx

POS	Artikelnr.	Beschreibung	Anzahl	Einheit
1	7.306-080.0	Zyl.Schr. M12x 30-8.8-A2E DIN 912	2.000	ST
2	6.503-035.0	Hydraulikmotor OR 160	1.000	ST
3	4.058-349.0	Radgabel kpl. Benzin	1.000	ST
4	7.312-277.0	Scheibe 8-200HV-A2E ISO7093-1	1.000	ST
6	7.306-044.0	Zyl.Schr. M8x35 -8.8-A2E ISO4762	1.000	ST
7	6.401-282.0	Schleifring 40	1.000	ST
8	7.306-063.0	Zyl.Schr. M10x30-8.8-A3E ISO4762	8.000	ST
9	4.058-353.0	Lagerung Vorderrad kpl.	1.000	ST
10	6.401-263.0	Schleifring	1.000	ST
11	7.312-010.0	Scheibe 24 -200HV-A3E ISO 7090	1.000	ST
12	7.311-122.0	6kt-Mutter M24X1,5-22H-A2E DIN 936	1.000	ST
13	6.432-282.0	Rollenkette 1/2x3/16	1.000	ST
14	6.432-062.0	Verschlussglied	1.000	ST
15	7.311-059.0	6kt-Mutter M16x1,5 -8-A2E ISO10512	1.000	ST
16	7.312-019.0	Scheibe 16-200HV-A3E ISO7090	1.000	ST
17	6.432-089.0	Kettenrad 11Z	1.000	ST
18	7.318-084.0	Passfeder 5x5x12 -C45R DIN 6885-1	1.000	ST
19	7.311-511.0	6kt-Mutter M10-8-A2E ISO 7040	4.000	ST
21	7.306-063.0	Zyl.Schr. M10x30-8.8-A3E ISO4762	4.000	ST
22	4.058-352.0	Lenksaeule kpl.	1.000	ST
23	7.303-112.0	Schraube 6x20 -10.9-R2R (In6Rd)	8.000	ST
24	7.306-051.0	Schraube M3x6 -8.8-A2K (In6Rd)	5.000	ST
25	5.095-424.0	Blech Halter Lenksaeule	1.000	ST
26	6.403-077.0	Gleitlager D 25	1.000	ST
27	5.110-561.0	Huelse	1.000	ST
28	6.435-795.0	Lenkrad	1.000	ST
29	6.640-353.0	Abdeckkappe Lenkrad KÄRCHER	1.000	ST
30	5.095-579.0	Blech Halter Lager	1.000	ST
31	6.401-480.0	Gelenklager D 25	1.000	ST
32	7.311-092.0	6kt-Mutter M18x1,5 -A2-035 ISO 8675	1.000	ST
33	6.401-260.0	Schraegkugellager	1.000	ST
34	7.401-035.0	Kugellager 7307B-TN DIN 628	1.000	ST
35	6.503-050.0	Passfeder 10x8x45	1.000	ST

30 Lenkung Verbrenner KM 105_1xx

POS	Artikelnr.	Beschreibung	Anzahl	Einheit
36	5.115-027.0	Scheibe Lager Lenkung	2.000	ST

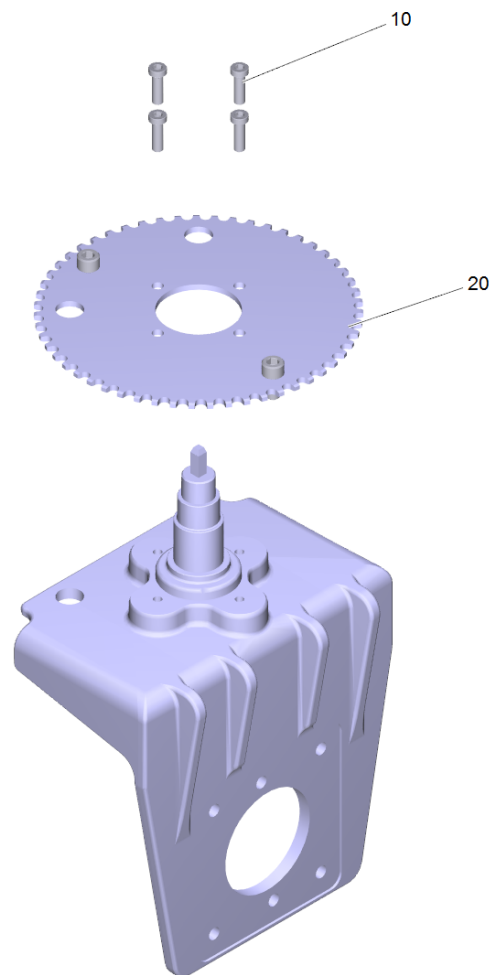

3 Radgabel kpl. Benzin (4.058-349.0)

POS	Artikelnr.	Beschreibung	Anzahl	Einheit
10	7.306-269.0	Schraube M8x16 -8.8-A2E ISO 7380-1	4.000	ST
20	4.058-487.0	Kettenrad kpl. mit Anschlag	1.000	ST

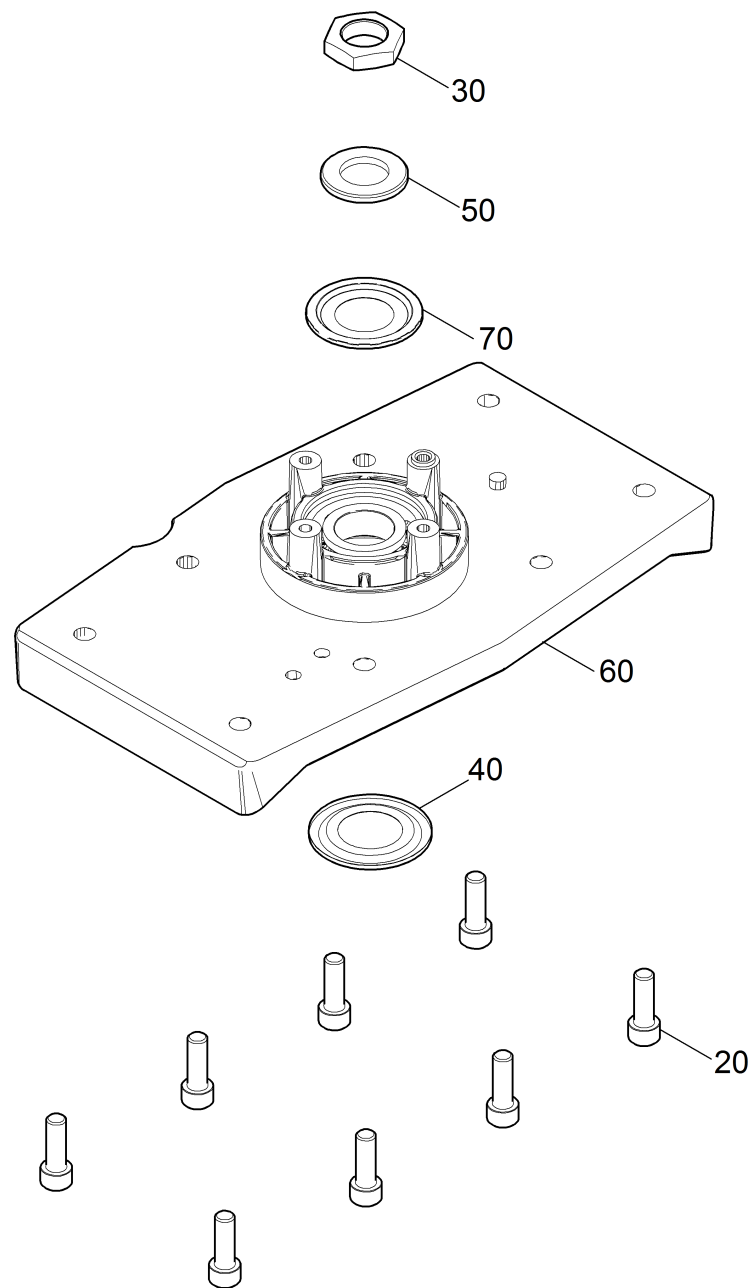

9 Lagerung Vorderrad kpl. (4.058-353.0)

POS	Artikelnr.	Beschreibung	Anzahl	Einheit
10	6.869-072.0	Metallkleber	0.050	ZST
20	7.306-063.0	Zyl.Schr. M10x30-8.8-A3E ISO4762	8.000	ST
30	7.311-122.0	6kt-Mutter M24X1,5-22H-A2E DIN 936	1.000	ST
40	6.401-282.0	Schleifring 40	1.000	ST
50	7.312-010.0	Scheibe 24 -200HV-A3E ISO 7090	1.000	ST
60	4.251-054.0	Lagerbock kpl.	1.000	ST
70	6.401-263.0	Schleifring	1.000	ST

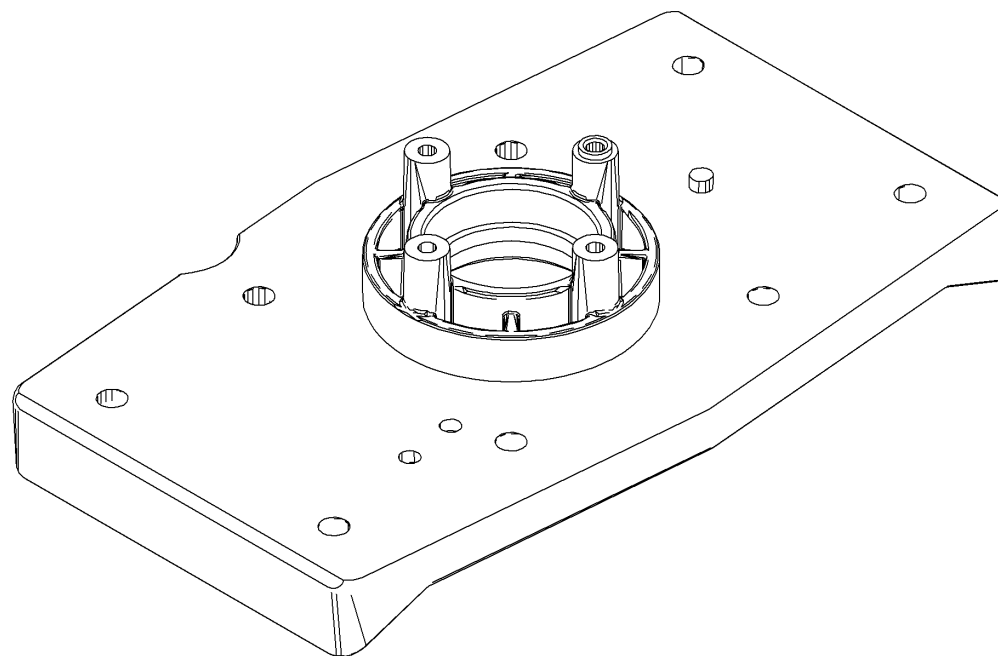
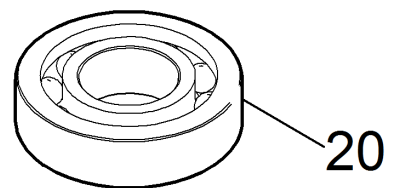
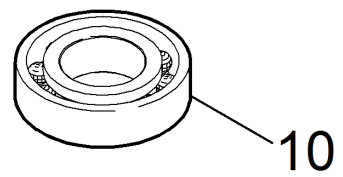

60 Lagerbock kpl. (4.251-054.0)

POS	Artikelnr.	Beschreibung	Anzahl	Einheit
10	6.401-260.0	Schraegkugellager	1.000	ST
20	7.401-035.0	Kugellager 7307B-TN DIN 628	1.000	ST

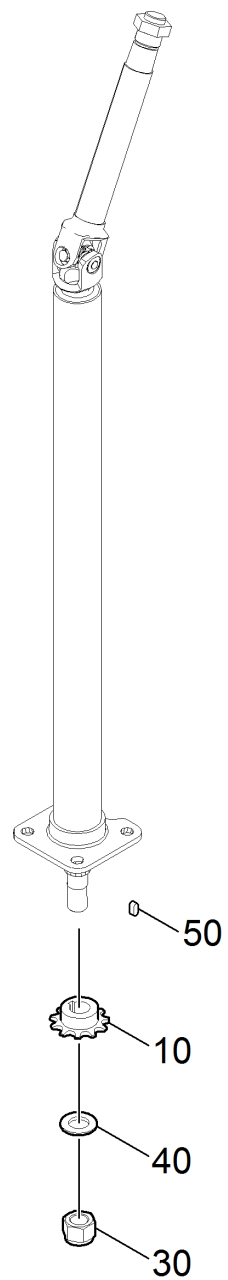

22 Lenksaeule kpl. (4.058-352.0)

POS	Artikelnr.	Beschreibung	Anzahl	Einheit
10	6.432-089.0	Kettenrad 11Z	1.000	ST
30	7.311-059.0	6kt-Mutter M16x1,5 -8-A2E ISO10512	1.000	ST
40	7.312-019.0	Scheibe 16-200HV-A3E ISO7090	1.000	ST
50	7.318-084.0	Passfeder 5x5x12 -C45R DIN 6885-1	1.000	ST

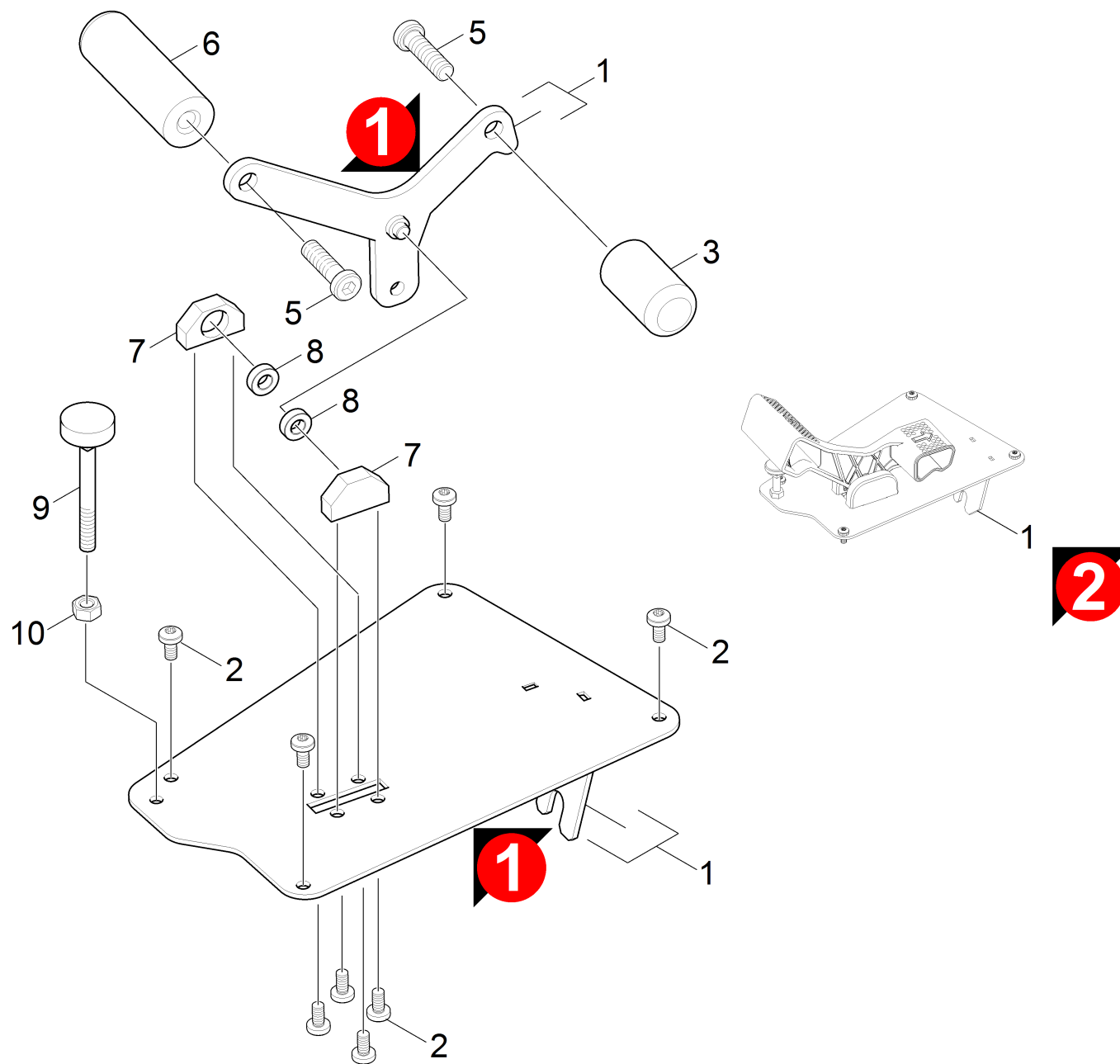

40 Pedal kpl. Verbrenner

POS	Artikelnr.	Beschreibung	Anzahl	Einheit
1	2.852-199.0	Pedal Guss Verbrenner	1.000	ST
2	7.306-089.0	Schraube M6x12 -8.8-R2R (In6Rd)	8.000	ST
3	5.321-701.0	Griff	1.000	ST
5	7.306-224.0	Schraube M10x35-A2-70 DIN 7984	2.000	ST
6	5.321-702.0	Griff	1.000	ST
7	5.251-047.0	Lagerbock	2.000	ST
8	7.401-174.0	Kugellager 688-2Z -Wälzl.St DIN 625	2.000	ST
9	5.317-807.0	Bolzen Anschlag Fahrpedal	1.000	ST
10	7.311-093.0	6kt-Mutter M8 -8-R2R ISO 4032	1.000	ST

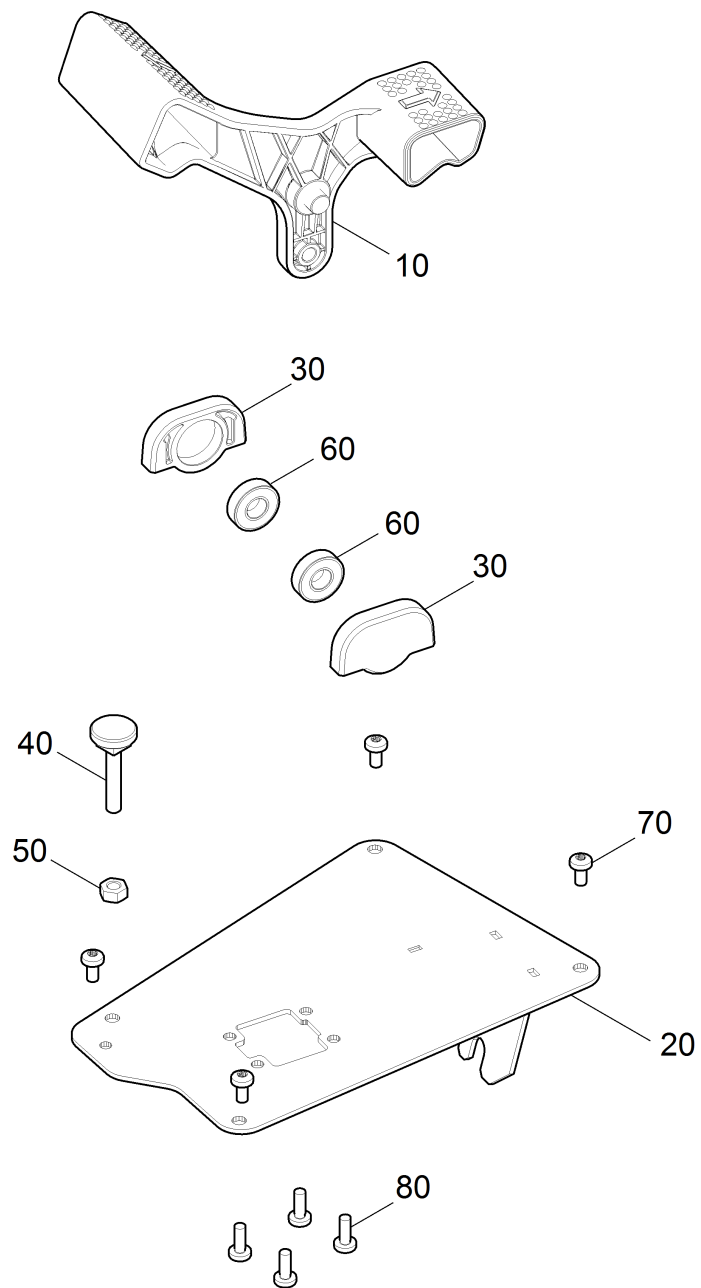

1 Pedal Guss Verbrenner (2.852-199.0)

POS	Artikelnr.	Beschreibung	Anzahl	Einheit
10	5.481-455.0	Pedal Guss Verbrenner M-Range	1.000	ST
20	4.058-562.0	Blech Pedal kpl. Guss	1.000	ST
30	5.251-001.0	Lagerbock Pedal	2.000	ST
40	5.317-807.0	Bolzen Anschlag Fahrpedal	1.000	ST
50	7.311-093.0	6kt-Mutter M8 -8-R2R ISO 4032	1.000	ST
60	7.401-111.0	Kugellager 6001-2RS -WAE LZLAGST DIN 625	2.000	ST
70	7.306-089.0	Schraube M6x12 -8.8-R2R (In6Rd)	4.000	ST
80	7.306-090.0	Schraube M6x16 -8.8-R3R (In6Rd)	4.000	ST

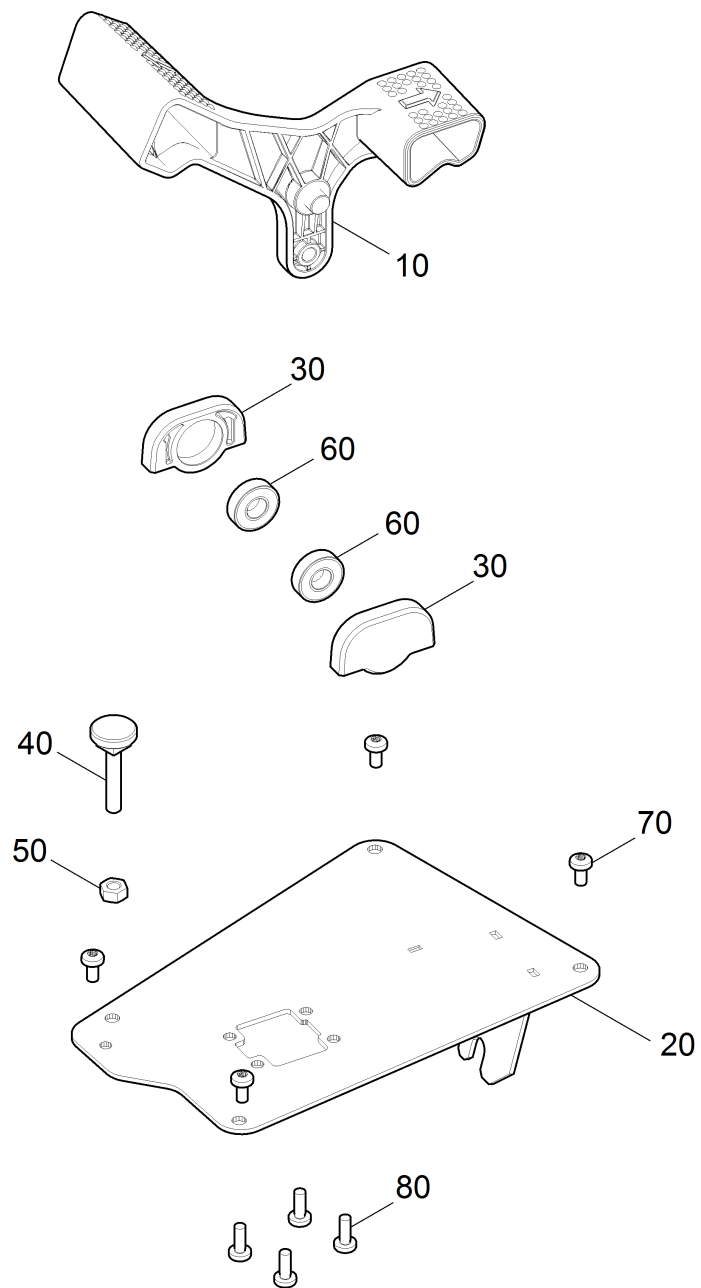

40 Pedal Guss Verbrenner (2.852-199.0)

POS	Artikelnr.	Beschreibung	Anzahl	Einheit
10	5.481-455.0	Pedal Guss Verbrenner M-Range	1.000	ST
20	4.058-562.0	Blech Pedal kpl. Guss	1.000	ST
30	5.251-001.0	Lagerbock Pedal	2.000	ST
40	5.317-807.0	Bolzen Anschlag Fahrpedal	1.000	ST
50	7.311-093.0	6kt-Mutter M8 -8-R2R ISO 4032	1.000	ST
60	7.401-111.0	Kugellager 6001-2RS -WAE LZLAGST DIN 625	2.000	ST
70	7.306-089.0	Schraube M6x12 -8.8-R2R (In6Rd)	4.000	ST
80	7.306-090.0	Schraube M6x16 -8.8-R3R (In6Rd)	4.000	ST

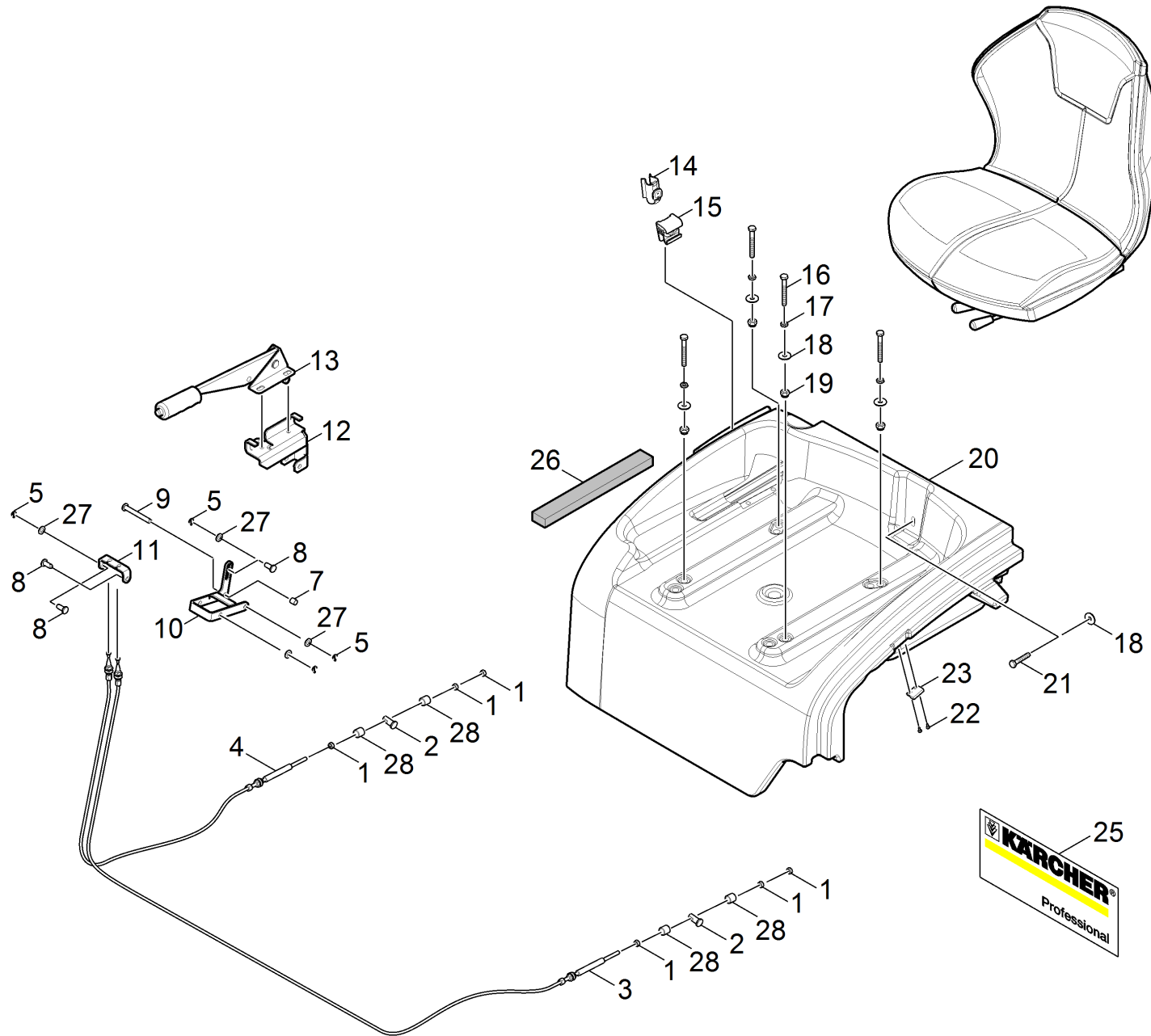

50 Haube rechts Verbrenner

POS	Artikelnr.	Beschreibung	Anzahl	Einheit
1	7.311-003.0	6kt-Mutter M6 -8-A2E ISO 4032	6.000	ST
2	5.111-371.0	Handbremsseil Adapter	2.000	ST
3	6.431-303.0	Bowdenzug links kpl.	1.000	ST
4	6.431-302.0	Bowdenzug rechts kpl.	1.000	ST
5	7.316-336.0	Splint 2x16-St-A2E ISO 1234	4.000	ST
7	5.111-205.0	Huelse	1.000	ST
8	7.316-224.0	Bolzen B8,0x18-ST-A2E ISO 2341	3.000	ST
9	7.316-043.0	Bolzen B 8x65 -St-A2E ISO 2341	1.000	ST
10	5.095-482.0	Blech Umlenkung Handbremse	1.000	ST
11	5.095-483.0	Blechteil Verteiler Handbremse	1.000	ST
12	2.643-753.0	Halter Handbremse Ersatz	1.000	ST
13	6.467-020.0	Handbremshebel	1.000	ST
14	6.980-078.0	Halter Griff grau	1.000	ST
15	5.035-488.0	Adapter Homepage	1.000	ST
16	7.304-402.0	6kt-Schraube M8x65-8.8-A2E ISO 4017	4.000	ST
17	7.311-224.0	6kt-Mutter M 8-04-A2E ISO 4035	4.000	ST
18	7.312-277.0	Scheibe 8-200HV-A2E ISO7093-1	5.000	ST
19	7.311-427.0	6kt-Mutter M8 -04-A2E ISO 10511	4.000	ST
20	5.033-798.0	Haube rechts Verbrenner KM 1xx/1xx	1.000	ST
21	7.304-407.0	6kt-Schraube M 8x45-8.8-A2E ISO 4017	1.000	ST
22	7.303-242.0	Schraube 3x10 -A2-70 (IN6RD)	2.000	ST
23	6.632-515.0	Magnet in Gehaeuse	1.000	ST
25	5.393-777.0	Schild Seite Professional 275x109	1.000	ST
26	6.286-606.0	Dichtung	1.000	ST
28	5.112-493.0	Buchse	4.000	ST

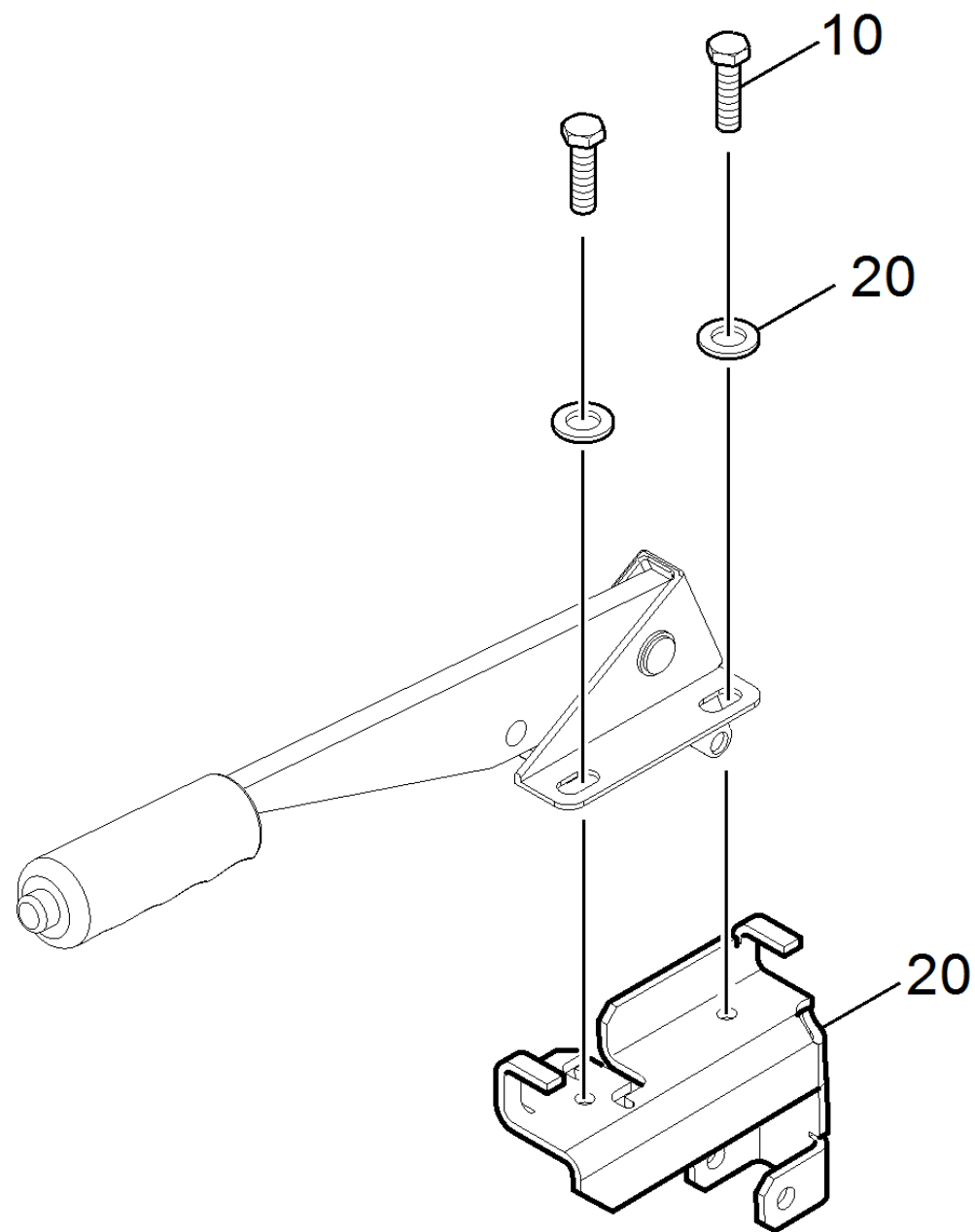

12 Halter Handbremse Ersatz (2.643-753.0)

POS	Artikelnr.	Beschreibung	Anzahl	Einheit
10	7.304-404.0	6kt-Schraube M8x40-8.8-A2E ISO 4017	2.000	ST
20	7.312-004.0	Scheibe 8 -200HV-A3E ISO 7090	2.000	ST
30	5.095-280.0	Halter Handbremse	1.000	ST

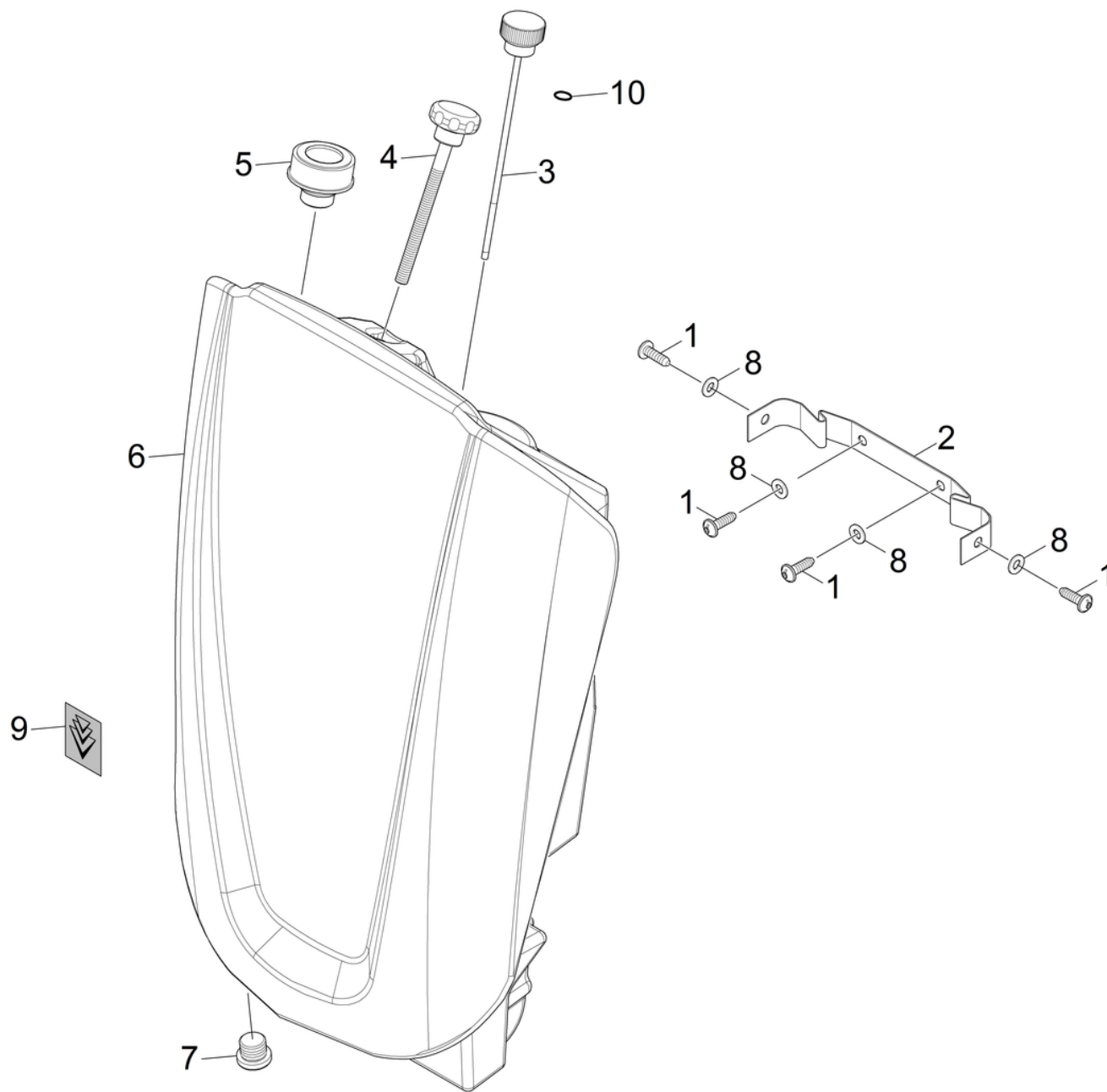

80 Oeltank Hydraulik KM 1xx_1xx

POS	Artikelnr.	Beschreibung	Anzahl	Einheit
1	7.303-112.0	Schraube 6x20 -10.9-R2R (In6Rd)	4.000	ST
2	6.373-994.0	Gurtband Oeltank	1.000	ST
3	6.417-062.0	Oelmessstab Hydraulik	1.000	ST
4	6.321-255.0	Sterngriff	1.000	ST
5	6.369-722.0	Entluefter	1.000	ST
6	5.033-792.0	Oeltank Hydraulik	1.000	ST
7	6.997-539.0	Verschlussschraube (VSTIR38ED)	1.000	ST
8	7.312-260.0	Scheibe 6 -100HV-A3E ISO 7094	4.000	ST
9	5.394-087.0	Aufkleber Signet Gel 102x113	1.000	ST
10	6.362-153.0	O-Ring 15,3 X 2,4-NBR 70	2.000	ST

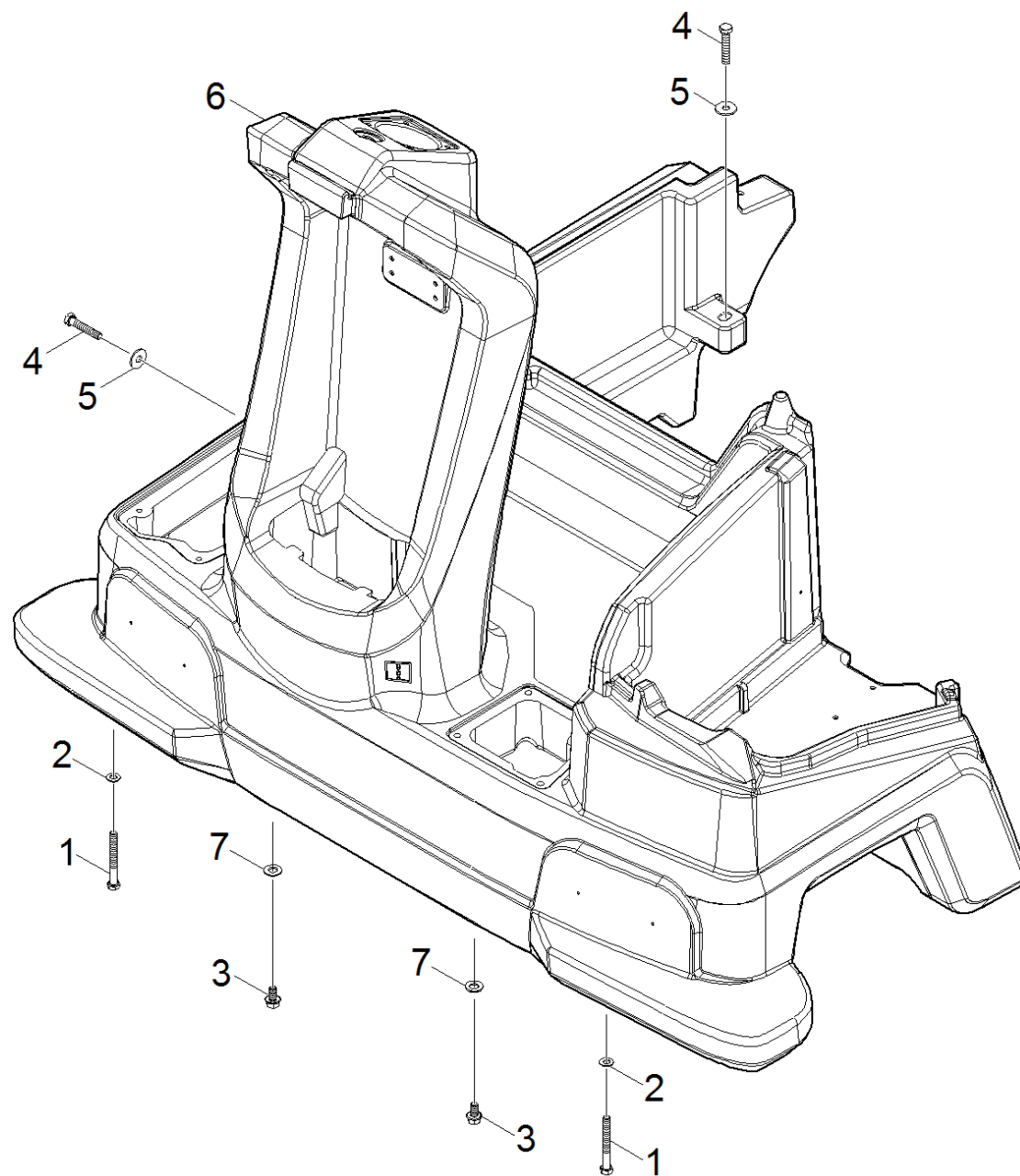

90 Frontteil KM 105_1xx

POS	Artikelnr.	Beschreibung	Anzahl	Einheit
1	7.304-097.0	6kt-Schraube M8x70-8.8-A2E ISO 4014	2.000	ST
2	7.312-004.0	Scheibe 8 -200HV-A3E ISO 7090	2.000	ST
3	7.304-051.0	6kt-Schraube M 8x16-8.8-P2R EN 1665	2.000	ST
4	7.304-407.0	6kt-Schraube M 8x45-8.8-A2E ISO 4017	2.000	ST
5	7.312-277.0	Scheibe 8-200HV-A2E ISO7093-1	2.000	ST
6	5.033-799.0	Frontteil KM 105/110	1.000	ST
7	7.312-277.0	Scheibe 8-200HV-A2E ISO7093-1	2.000	ST

20 Elektronik Verbrenner KM 1xx_1xx

POS	Artikelnr.	Beschreibung	Anzahl	Einheit
10	5.972-237.0	ETL Elektronik Verbrenner KM 1xx/1xx	1.000	ST

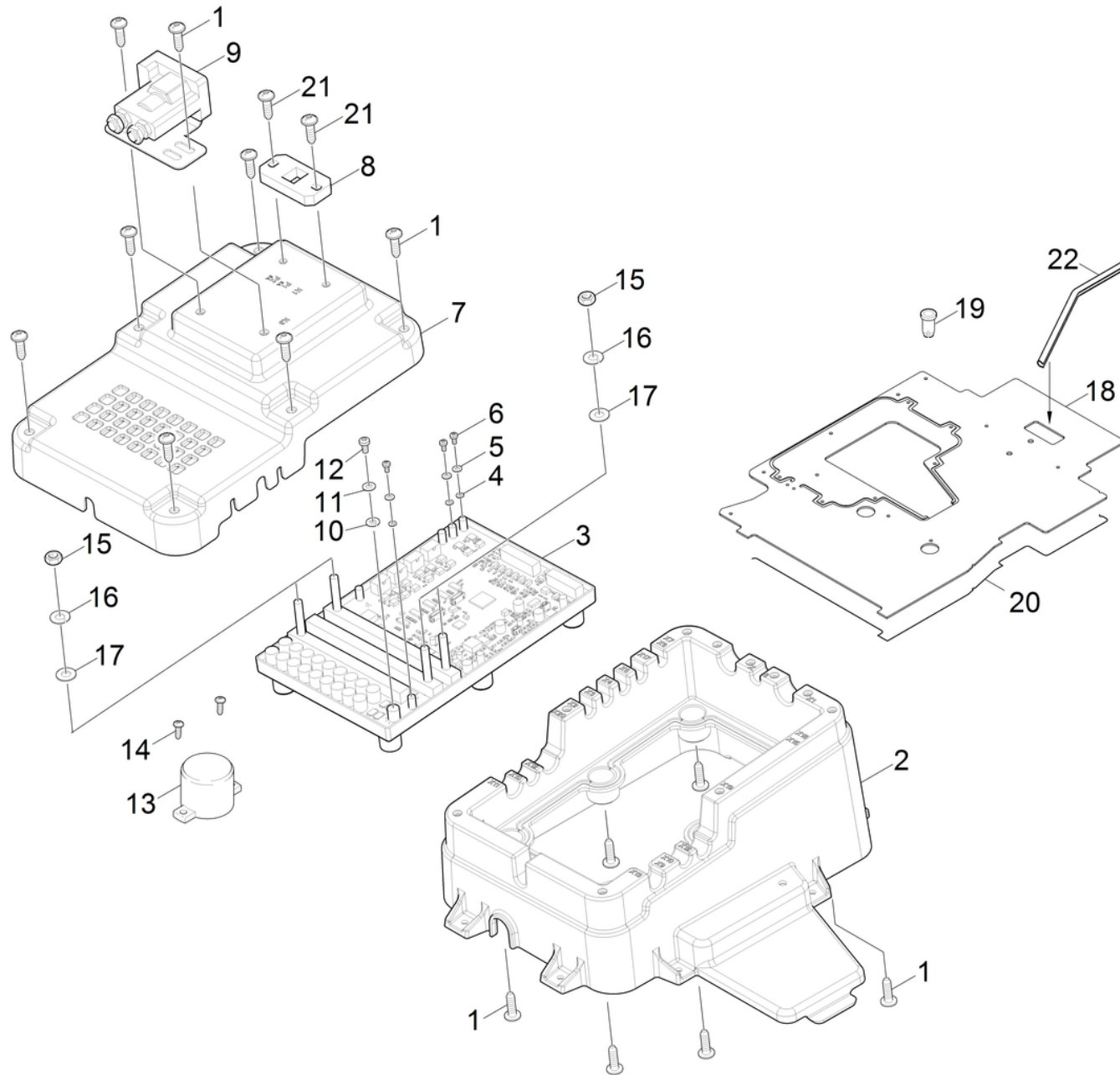

10 ETL Elektronik Verbrenner KM 1xx/1xx (5.972-237.0)

POS	Artikelnr.	Beschreibung	Anzahl	Einheit	Fußnotentext
1	6.303-125.0	Schraube 5x20-Sonder In6Rd+Spitze	14.000	ST	
2	5.033-869.0	Topf Multifunktionsmodul	1.000	ST	
3	4.683-013.0	Platine verpackt nur fuer Ersatz	1.000	ST	
4	7.313-000.0	Federring B 3-FSt-A3E DIN 127	3.000	ST	
5	7.312-120.0	Scheibe 3 -200HV-ZNSHL ISO 7089	3.000	ST	
6	7.306-051.0	Schraube M3x6 -8.8-A2K (In6Rd)	3.000	ST	
7	5.033-870.0	Deckel Multifunktionsmodul	1.000	ST	
8	6.644-276.0	Platte	1.000	ST	
9	6.633-411.0	Leistungsrelais	1.000	ST	
10	7.313-001.0	Federring B 4-FSt-A3E DIN 127	1.000	ST	
11	7.312-001.0	Scheibe 4 -200HV-A3E ISO 7089	1.000	ST	
12	7.306-056.0	Schraube M4x8 -8.8-R2R (In6Rd)	1.000	ST	
13	6.630-752.0	Summer mit Buchse	1.000	ST	
14	7.303-095.0	Schraube 4x 12-ST-10.9-R2R (IN6RD)	2.000	ST	
15	7.311-003.0	6kt-Mutter M6 -8-A2E ISO 4032	4.000	ST	
16	7.313-003.0	Federring B 6-FSt-A3E DIN 127	4.000	ST	
17	7.312-003.0	Scheibe 6 -200HV-A3E ISO 7090	4.000	ST	
18	5.033-883.0	Staubschutz Benzin rechts	1.000	ST	
19	6.310-194.0	Spreizniet Kunststoff D5	18.000	ST	
20	6.273-055.0	Profildichtung	1.000	M	ALS METERWARE BESTELLEN
21	6.303-125.0	Schraube 5x20-Sonder In6Rd+Spitze	2.000	ST	
22	6.368-089.0	Kantenschutz	1.000	M	ALS METERWARE BESTELLEN
100	4.822-862.0	Adapterkabel Servicemodul Y-Split	1.000	ST	
200	4.822-866.0	Anschlusskabel Serviceschnittstelle	1.000	ST	

40 Starter Generator 60 A

POS	Artikelnr.	Beschreibung	Anzahl	Einheit
0	5.972-240.0	ETL Starter Generator 60 A - KM Medium	1.000	ST

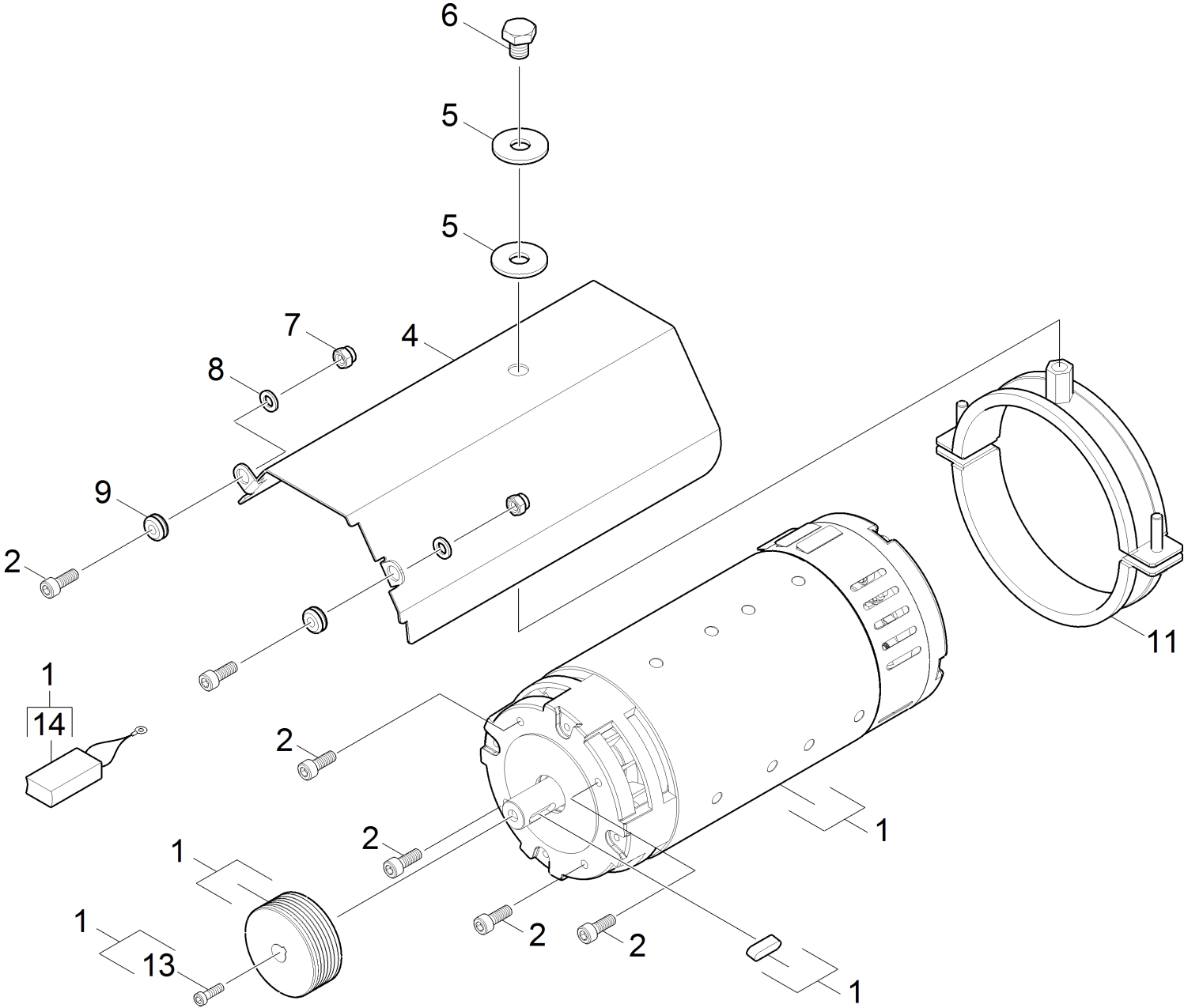

ETL Starter Generator 60 A - KM Medium (5.972-240.0)

POS	Artikelnr.	Beschreibung	Anzahl	Einheit
1	4.613-006.0	Starter Generator montiert 60 A	1.000	ST
2	7.306-031.0	Schraube M 6x16-A2-70 DIN 7984	6.000	ST
4	5.095-593.0	Blech Spritzschutz Generator 60A	1.000	ST
5	7.312-285.0	Scheibe 10 -200HV-A2E ISO7093-1	2.000	ST
6	7.304-409.0	6kt-Schraube M10x12-8.8-A3E ISO 4017	1.000	ST
7	7.311-512.0	6kt-Mutter M 6-8-A2E ISO 7040	2.000	ST
8	7.312-045.0	Scheibe 6-200HV-P4E ISO 7089	2.000	ST
9	6.641-638.0	Durchfuehrungstuelle	2.000	ST
11	6.373-447.0	Rohrschelle D116	1.000	ST
13	7.306-031.0	Schraube M 6x16-A2-70 DIN 7984	1.000	ST
14	2.643-443.0	Kohlebuerstensatz Starter 60/90A	1.000	ST

50 Kabelsatz Diesel kpl. KM 105/110 R D

POS	Artikelnr.	Beschreibung	Anzahl	Einheit
0	5.972-304.0	ETL Kabelsatz Diesel KM 105/110	1.000	ST

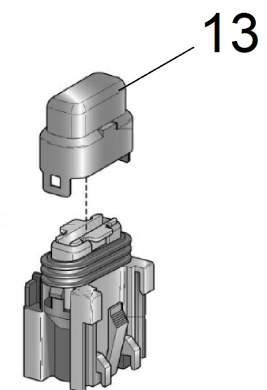
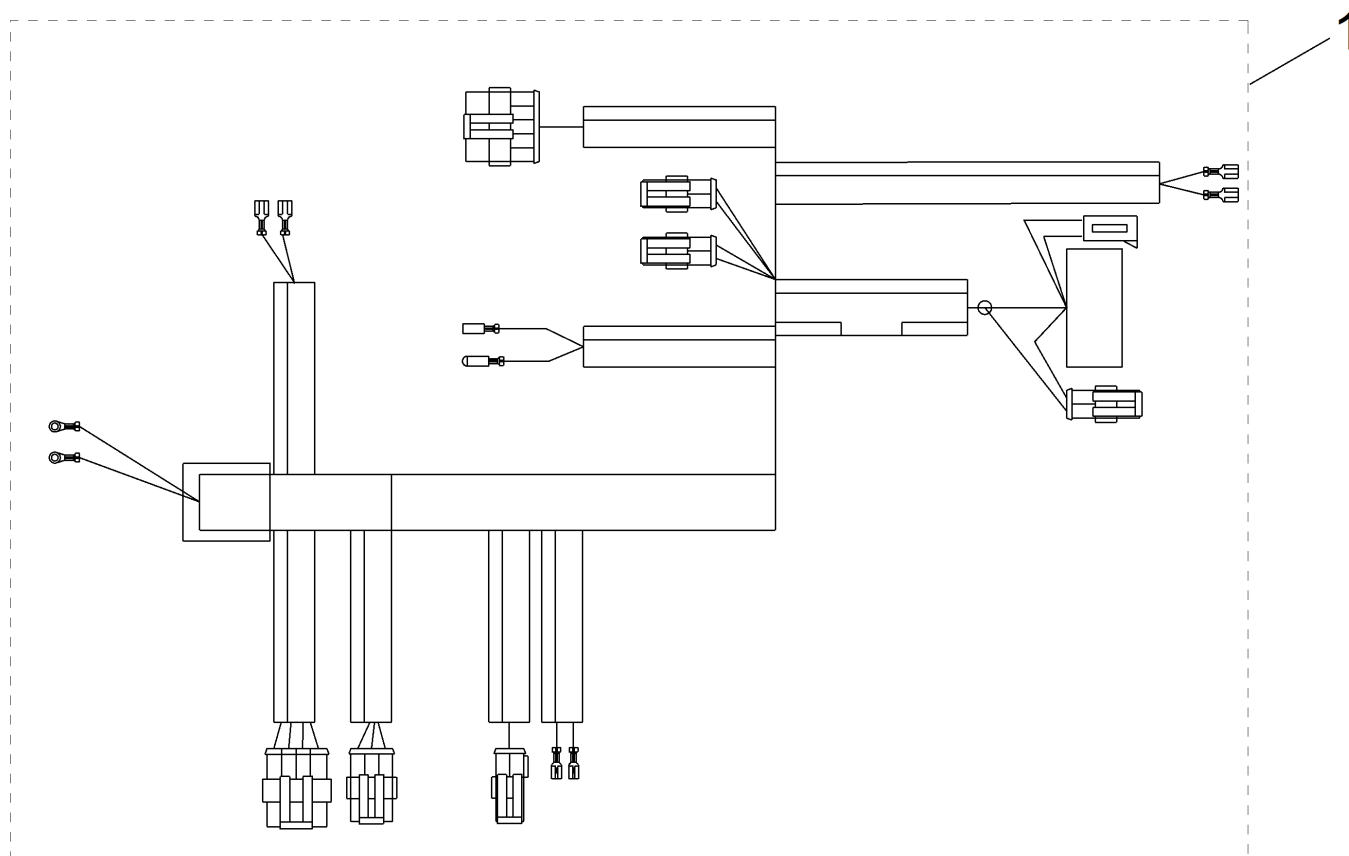
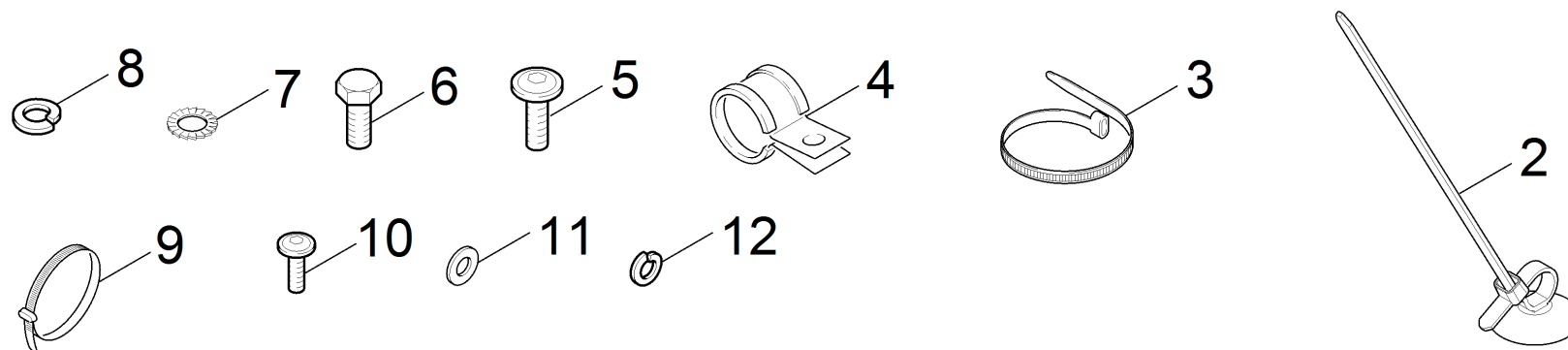

ETL Kabelsatz Diesel KM 105/110 (5.972-304.0)

POS	Artikelnr.	Beschreibung	Anzahl	Einheit
1		Kabelsatz Diesel KM 105/110 R D	1.000	ST
2	6.650-265.0	Kabelbinder mit Befestigung	8.000	ST
3	6.647-081.0	Kabelband	30.000	ST
4	6.373-212.0	Rohrschelle	1.000	ST
5	7.303-112.0	Schraube 6x20 -10.9-R2R (In6Rd)	1.000	ST
6	7.304-535.0	6kt-Schraube M8x25-A4-70 ISO 4017	2.000	ST
7	7.312-022.0	Faecherscheibe A8,4-1.4310 DIN6798	2.000	ST
8	7.313-015.0	Federring B 8-1.4310 DIN 127	2.000	ST
9	6.641-463.0	Kabelband	10.000	ST
10	7.306-071.0	Schraube M5x10 -8.8-R2R (In6Rd)	1.000	ST
11	7.312-002.0	Scheibe 5-200HV-A3E ISO 7090	1.000	ST
12	7.313-002.0	Federring B 5-FSt-A3E DIN 127	1.000	ST
13	6.644-062.0	Sicherungshalter wasserdicht	2.000	ST

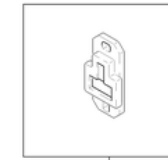
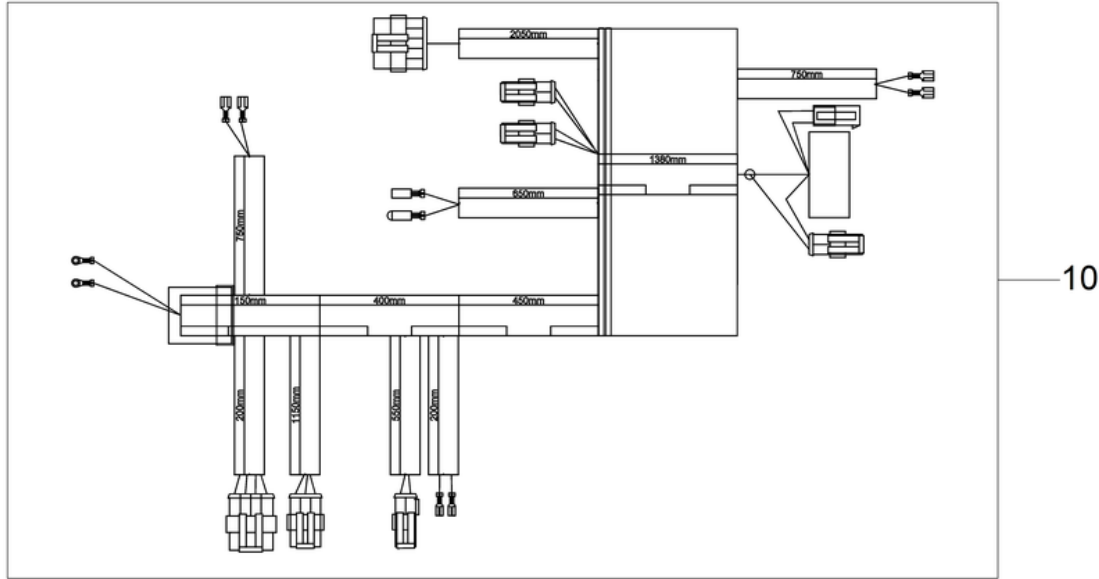

20

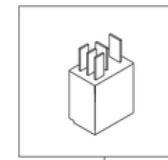

30

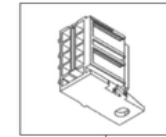

40

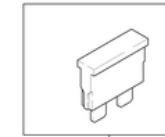

50

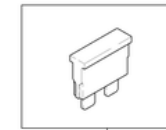

60

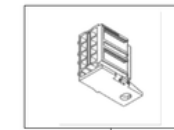

70

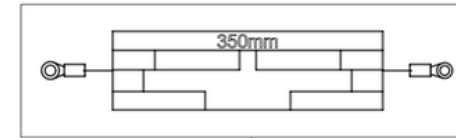

110

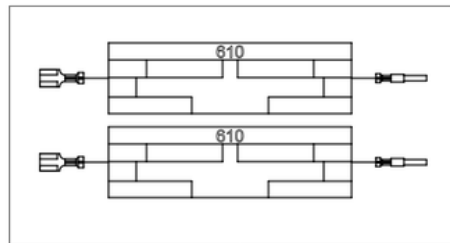

80

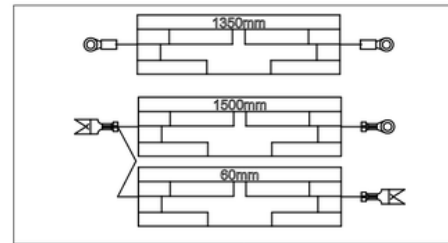

90

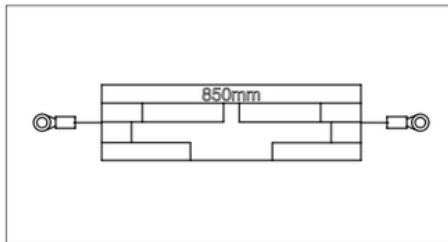

100

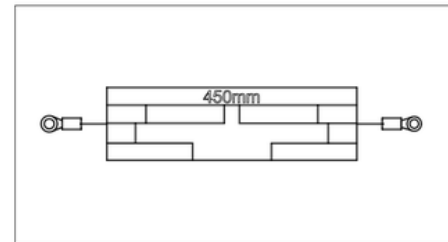

120

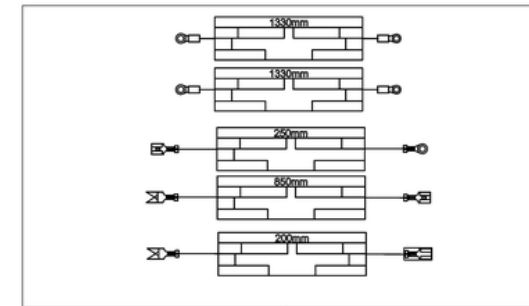

130

1 Kabelsatz Diesel KM 105/110 R D

POS	Artikelnr.	Beschreibung	Anzahl	Einheit
10	6.683-481.0	Hauptkabel Diesel KM 105/110 RD	1.000	ST
20	6.644-276.0	Platte	1.000	ST
30	6.633-007.0	Mikrorelais Wechsler 12V	1.000	ST
40	6.644-610.0	Halter Flachsicherung mini	1.000	ST
50	6.644-607.0	Flachsicherung mini 7,5A	1.000	ST
60	6.644-606.0	Flachsicherung mini 5A	1.000	ST
70	6.633-008.0	Sockel Mikrorelais	1.000	ST
80	6.683-459.0	Kabel Schalter Sitz W2.1,WXS10	1.000	ST
90	6.683-483.0	Kabel Batterie G1W1+	1.000	ST
100	6.683-484.0	Kabel Batterie G1W1-	1.000	ST
110	6.683-486.0	Kabel Relais Steuerung + 350mm	1.000	ST
120	6.683-487.0	Kabel Steuerung - 450mm	1.000	ST
130	6.683-485.0	Kabel Versorgung Anlasser WM 21	1.000	ST
140	6.683-489.0	Kabel Erdung Motor	1.000	ST

60 Rumpfgeraet Hochentleerung KM 105_110

POS	Artikelnr.	Beschreibung	Anzahl	Einheit
0	5.972-223.0	ETL Rumpfgeraet Hochentleerung KM 105/11	1.000	ST

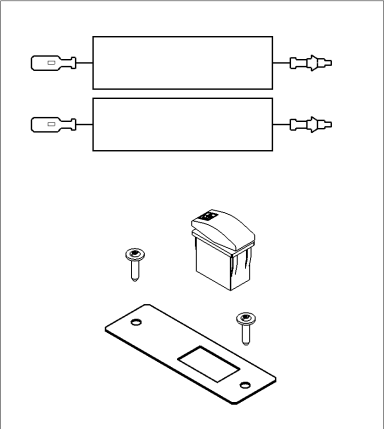

2

60

1

60

120

50

70

30

40

80

90

110

110

ETL Rumpfgeraet Hochentleerung KM 105/11 (5.972-223.0)

POS	Artikelnr.	Beschreibung	Anzahl	Einheit	Fußnotentext
10		Hochentleerung KM 105_110	1.000	ST	
20		Filterkasten APFC KM 105_110	1.000	ST	
30	2.851-420.0	Bedienfeld Verbrenner KM 105_110	1.000	ST	
40	6.413-555.0	Steuerblock	1.000	ST	
50	6.504-116.0	Hubzylinder Hochentleerung 12V	1.000	ST	
60	2.643-954.0	Set Taster	1.000	ST	
70	4.035-542.0	Set Schluessel gelb KIK KM	1.000	ST	
80	6.413-578.0	Spule 12V - ZSV01032A/F	3.000	ST	
90	6.362-480.0	O-Ring 12,42x 1,78	6.000	ST	
100	6.413-577.0	Raendelmutter M16 - ZSV01236A/F	1.000	ST	
110	6.413-576.0	Raendelmutter M12x1,25 - ZSV02359A/F	1.000	ST	
120	6.273-055.0	Profildichtung	1.000	M	ALS METERWARE BESTELLEN

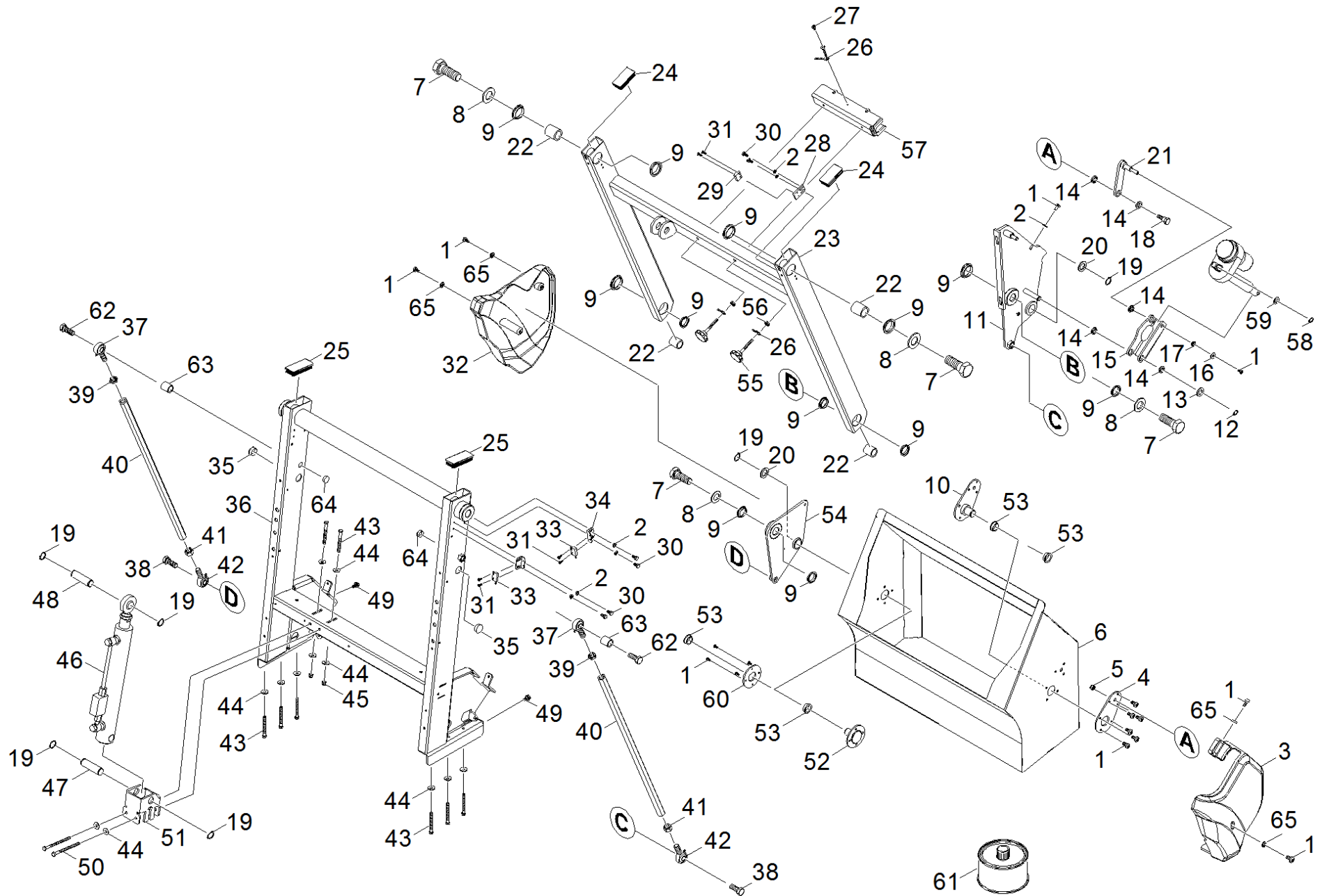

10 Hochentleerung KM 105_110

POS	Artikelnr.	Beschreibung	Anzahl	Einheit
1	7.306-192.0	Schraube M 6x 12-A2-70 (In6Rd)	15.000	ST
2	7.312-026.0	Scheibe 6 -A2 ISO 7090	6.000	ST
3	5.033-863.0	Verkleidung Hochentleerung links	1.000	ST
4	5.095-205.0	Blechteil Gegenhalter Kehrbehälter	1.000	ST
5	7.311-524.0	6kt-Mutter M10-A2-70 ISO 7040	1.000	ST
6	4.058-332.0	Kehrbehälter Blech schmal	1.000	ST
7	7.304-151.0	6kt-Schraube M30x80 -8.8-A3E ISO 4017	4.000	ST
8	7.312-070.0	Scheibe 30-A2 ISO 7089	4.000	ST
9	6.403-053.0	Gleitlager DM40x10	8.000	ST
10	4.058-281.0	Lagerung Kehrbehälter rechts	1.000	ST
11	4.058-280.0	Blechteil Parallelogramm links	1.000	ST
12	7.343-015.0	Sicherungsring 15x1-FST-RF DIN 471	1.000	ST
13	5.115-608.0	Scheibe	1.000	ST
14	5.250-190.0	Gleitlager	5.000	ST
15	5.095-336.0	Blech Schubstange lang	1.000	ST
16	7.312-260.0	Scheibe 6 -100HV-A3E ISO 7094	1.000	ST
17	6.437-482.0	BUNDBUCHSE D10	1.000	ST
18	5.111-300.0	Bundschraube M10	1.000	ST
19	7.343-008.0	Sicherungsring 25x1,2-St-vz DIN 471	6.000	ST
20	5.115-924.0	Scheibe Parallelogramm SM	2.000	ST
21	4.058-358.0	Blech Schubstange kpl.	1.000	ST
22	5.111-260.0	Buchse Hochentleerung	4.000	ST
23	4.058-277.0	Hebearm KM 105/1xx R	1.000	ST
24	6.368-445.0	Schutzstopfen 40x80	2.000	ST
25	6.368-446.0	Schutzstopfen 40x100	2.000	ST
26	6.997-410.0	Kette GN 111	2.000	ST
27	7.303-030.0	Schraube M4x8 -St-P2R (In6Rd)	1.000	ST
28	5.095-465.0	Halter Magnet	1.000	ST
29	6.632-515.0	Magnet in Gehäuse	1.000	ST
30	7.304-552.0	6kt-Schr. M 6x12-A4-70 ISO 4017	6.000	ST
31	7.306-203.0	Schraube M 3X 8-A2-70 (IN6RD)	6.000	ST
32	5.033-864.0	Verkleidung Hochentleerung rechts	1.000	ST
33	6.632-541.0	Reedsensor 650 mm	2.000	ST

10 Hochentleerung KM 105_110

POS	Artikelnr.	Beschreibung	Anzahl	Einheit
34	5.095-397.0	Halter Reedkontakt Hochentleerung	2.000	ST
35	6.368-296.0	Abdeckkappe D34.9	2.000	ST
36	4.058-278.0	Traeger Hochentleerung kpl.	1.000	ST
37	6.401-275.0	Gelenkkopf M16	2.000	ST
38	7.304-451.0	6kt-Schr. M16X 40-8.8-A3E ISO 4017	4.000	ST
39	7.311-213.0	6kt-Mutter M16 -04-A2E ISO 4035	2.000	ST
40	5.111-261.0	Stange Parallelogramm	2.000	ST
41	7.311-007.0	6kt-Mutter M16-LH-8-A2E ISO 4032	2.000	ST
42	6.401-276.0	Gelenkkopf M16-LH	2.000	ST
43	7.304-098.0	6kt-Schraube M8x80-8.8-A2E ISO 4014	8.000	ST
44	7.312-277.0	Scheibe 8-200HV-A2E ISO7093-1	12.000	ST
45	7.311-510.0	6kt-Mutter M 8-8-A2E ISO 7040	2.000	ST
46	6.504-103.0	Hydraulikzylinder Kehrbehaelter Anhebung	1.000	ST
47	5.111-314.0	Achse Hydraulikzylinder unten	1.000	ST
48	5.111-315.0	Achse Hydraulikzylinder oben	1.000	ST
49	7.304-051.0	6kt-Schraube M 8x16-8.8-P2R EN 1665	2.000	ST
50	7.304-463.0	6kt-Schraube M8x120 -A2-70 ISO 4017	2.000	ST
51	5.095-345.0	Blechteil Halter Hydraulikzylinder	1.000	ST
52	4.058-282.0	Lagerung Kehrbehaelter rechts	1.000	ST
53	5.250-082.0	Lager	4.000	ST
54	4.058-279.0	Blechteil Parallelogramm rechts	1.000	ST
55	6.321-249.0	Sterngriff	2.000	ST
56	7.311-510.0	6kt-Mutter M 8-8-A2E ISO 7040	2.000	ST
57	5.095-488.0	Blechteil Stuetze Hydraulikzylinder	1.000	ST
58	7.343-001.0	Sicherungsring 10x1-Rf-St DIN 471	1.000	ST
59	7.312-005.0	Scheibe 10-200HV-A3E ISO 7090	1.000	ST
60	5.095-207.0	Blechteil Gegenhalter Kehrbehaelter	1.000	ST
61	6.280-180.0	Schmierpaste GLEITMO 825,250gr	1.000	ST
62	7.304-002.0	6kt-Schraube M16x60-A4-70 ISO 4017	2.000	ST
63	5.112-463.0	Buchse	2.000	ST
64	6.368-103.0	Abdeckkappe 19	2.000	ST
65	7.312-276.0	Scheibe 6 -200HV-A2E ISO7093-1	7.000	ST

33 Reedsensor 650 mm (6.632-541.0)

POS	Artikelnr.	Beschreibung	Anzahl	Einheit
10	6.422-055.0	Steckergehaeuse 2-Wege Superseal 1.5	1.000	ST

10 Steckergehaeuse 2-Wege Superseal 1.5 (6.422-055.0)

POS	Artikelnr.	Beschreibung	Anzahl	Einheit
10	6.641-332.0	Kabel 0,5 ² für AMP Super Seal 1,5 Male	1.000	ST
20	6.641-334.0	Kabel 1,0 ² für AMP Super Seal 1,5 Male	1.000	ST

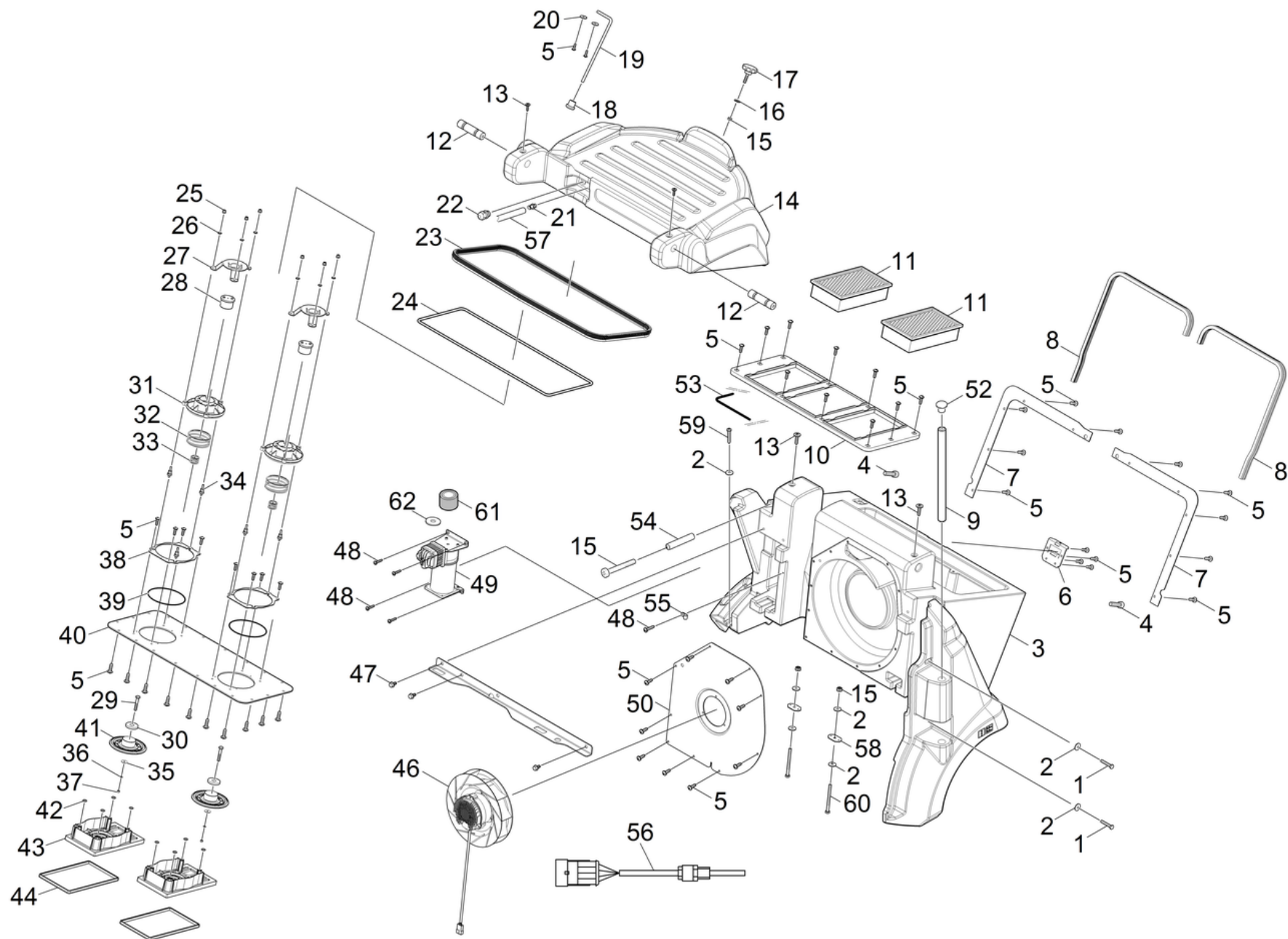

20 Filterkasten APFC KM 105_110

POS	Artikelnr.	Beschreibung	Anzahl	Einheit	Fußnotentext
1	7.304-407.0	6kt-Schraube M 8x45-8.8-A2E ISO 4017	2.000	ST	
2	7.312-277.0	Scheibe 8-200HV-A2E ISO7093-1	8.000	ST	
3	5.033-844.0	Filterkasten Hochentleerung klein	1.000	ST	
4	7.306-044.0	Zyl.Schr. M8x35 -8.8-A2E ISO4762	2.000	ST	
5	7.303-112.0	Schraube 6x20 -10.9-R2R (In6Rd)	33.000	ST	
6	5.095-304.0	Blechteil Verriegelung Deckel	1.000	ST	
7	5.095-293.0	Halter Dichtung	2.000	ST	
8	6.365-572.0	Dichtungsprofil doppelt Kammer	1.000	M	ALS METERWARE BESTELLEN
9	5.111-360.0	Achse Scharnier Filterkasten	1.000	ST	
10	5.069-334.0	Halter Flachfilter 2-fach	1.000	ST	
11	6.907-519.0	Flachfilter mit Verstrebung PES	2.000	ST	
12	5.111-306.0	Bolzen Lagerung Filterkasten	2.000	ST	
13	6.303-125.0	Schraube 5x20-Sonder In6Rd+Spitze	2.000	ST	
14	5.033-843.0	Filterdeckel Hochentleerung	1.000	ST	
15	7.304-463.0	6kt-Schraube M8x120 -A2-70 ISO 4017	1.000	ST	
16	7.312-004.0	Scheibe 8 -200HV-A3E ISO 7090	1.000	ST	
17	6.321-257.0	Sterngriff grau M8x43	1.000	ST	
18	6.641-446.0	Kabeltuelle	1.000	ZST	
19	5.107-003.0	Stange Deckel Filterkasten	1.000	ST	
20	7.312-276.0	Scheibe 6 -200HV-A2E ISO7093-1	2.000	ST	
21	6.512-011.0	Steckanschluss Nippel G1/8"	1.000	ST	
22	6.648-399.0	Kabelverschraubung schwarz M16x1,5	1.000	ST	
23	6.366-058.0	Dichtungsprofil	1.000	M	ALS METERWARE BESTELLEN
24	6.363-640.0	Moosgummischnur d=7mm	1.000	M	ALS METERWARE BESTELLEN
25	7.311-424.0	6kt-Mutter M4 -8-A2E ISO 7040	6.000	ST	
26	7.312-001.0	Scheibe 4 -200HV-A3E ISO 7089	6.000	ST	
27	5.095-538.0	Niederhalter Magnet	2.000	ST	
28	6.653-022.0	Magnet Abreinigung Filter 12 VDC	2.000	ST	
29	7.304-157.0	6kt-Schraube M5x30 -8.8-A2E ISO 4014	2.000	ST	
30	5.005-381.0	Platte Magnet	2.000	ST	
31	5.044-838.0	Halter Magnet	2.000	ST	
32	5.332-556.0	Feder weich	2.000	ST	
33	5.332-555.0	Feder hart	2.000	ST	

20 Filterkasten APFC KM 105_110

POS	Artikelnr.	Beschreibung	Anzahl	Einheit	Fußnotentext
34	5.111-288.0	Distanzbolzen kurz	6.000	ST	
35	6.312-147.0	Scheibe TOLDIN522-C-A2-5,3x20x1,5	2.000	ST	
36	7.333-008.0	Tellerfeder A10 -St EN 16983	2.000	ST	
37	7.311-029.0	6kt-Mutter M 5-A4-70 ISO 7042	2.000	ST	
38	5.095-546.0	Blechteil Gegenhalter O-Ring	2.000	ST	
39	6.362-447.0	O-Ring 115,0 X 1,78-NBR 70	2.000	ST	
40	5.095-311.0	Blechteil Unterteil Deckel	1.000	ST	
41	5.582-161.0	Ventilteller	2.000	ST	
42	6.362-703.0	O-Ring 6,0x1,5-NBR 70	14.000	ST	
43	5.069-336.0	Halter Feder	2.000	ST	
44	6.273-055.0	Profildichtung	1.000	M	ALS METERWARE BESTELLEN
46	6.484-329.0	Geblaese kpl.	1.000	ST	
47	7.304-051.0	6kt-Schraube M 8x16-8.8-P2R EN 1665	3.000	ST	
48	7.303-079.0	Bl.Schr. ST4,8X25-ST-A2R (IN6RD)	5.000	ST	
49	6.476-041.0	Luftpumpe 12 V	1.000	ST	
50	5.095-289.0	Blechteil Halter Geblaese	1.000	ST	
52	6.368-048.0	Zierkappe	1.000	ST	
53	6.273-070.0	Dichtschnur Moosgummi 4	1.000	M	ALS METERWARE BESTELLEN
54	6.996-095.0	Huelse	1.000	ST	
55	6.373-633.0	Rohrschelle	1.000	ST	
56	4.822-861.0	Kabelsatz Filterreinigung KM105/100, KM1	1.000	ST	
57	6.391-299.0	Schlauch	1.000	M	ALS METERWARE BESTELLEN
58	5.007-756.0	Blech	2.000	ST	
59	7.303-275.0	Schraube 8x50 -10.9-A3E (In6Rd)	1.000	ST	
60	7.304-454.0	6kt-Schraube M 8x100-8.8-A2E ISO 4017	2.000	ST	
61	6.476-047.0	Filter Luftpumpe	1.000	ST	
62	7.312-287.0	Scheibe 12-200HV-A2E ISO7093-1	1.000	ST	

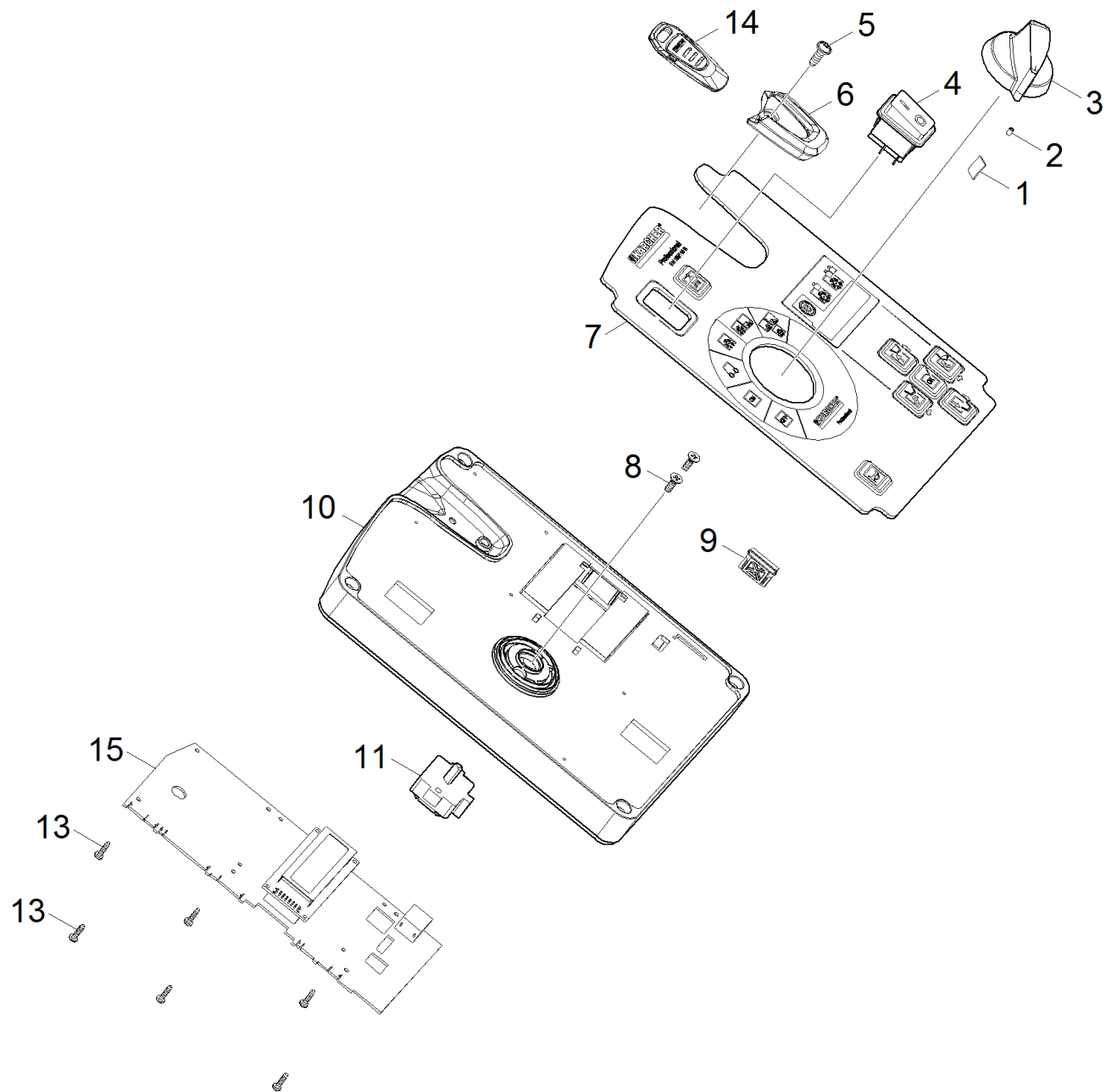

30 Bedienfeld Verbrenner KM 105_110 (2.851-420.0)

POS	Artikelnr.	Beschreibung	Anzahl	Einheit
1	6.313-014.0	Federungselement	1.000	ST
2	7.307-042.0	Gewindestift M3x5 -A2-21H ISO 4026	1.000	ST
3	5.321-738.0	Griff Bedienkonzept	1.000	ST
4	6.630-663.0	Schalter Hauptschalter 1 / 0	1.000	ST
5	7.303-107.0	Schraube 5x16 -10.9-P2R (K-In6Rd)	1.000	ST
6	5.035-343.0	Fuehrung Schluessel	1.000	ST
7	5.393-547.0	Folie Bedienfeld KM 105/110 R G/D/LPG	1.000	ST
8	7.305-255.0	Senkschr. M 4x12-A2-70-sw ISO7046-2 H1	2.000	ST
9	5.033-829.0	Gummistopfen Bedienpanel	1.000	ST
10	5.033-819.0	Bedienfeld Benzin KM	1.000	ST
11	6.630-476.0	Schalter Programmwahl	1.000	ST
13	6.303-557.0	Schraube 3x12 Kombitorx T8	6.000	ST
14	4.035-542.0	Set Schluessel gelb KIK KM	1.000	ST
14	5.035-944.0	KIK-Schluessel grau KM	1.000	ST
15	6.683-181.0	Platine Kopf-CPU Textdisplay KM 105_1xx	1.000	ST
100	6.650-300.0	Kabel Programmwahlschalter	1.000	ST

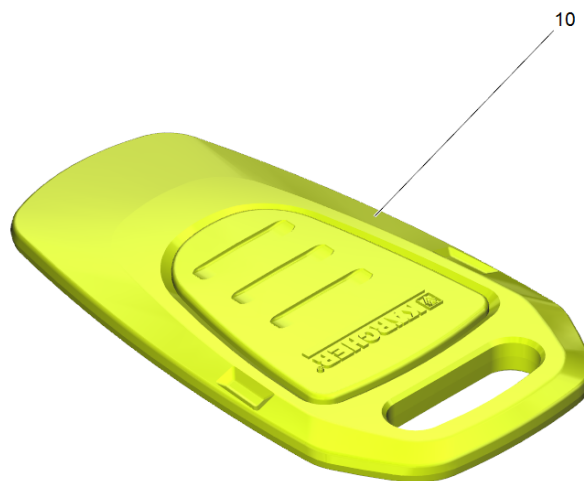

14 Set Schluessel gelb KIK KM (4.035-542.0)

POS	Artikelnr.	Beschreibung	Anzahl	Einheit
10	5.035-943.0	KIK-Schluessel gelb KM	5.000	ST

40 Steuerblock (6.413-555.0)

POS	Artikelnr.	Beschreibung	Anzahl	Einheit
999	6.413-578.0	Spule 12V - ZSV01032A/F	1.000	ST
999	6.413-577.0	Raendelmutter M16 - ZSV01236A/F	1.000	ST
999	6.413-576.0	Raendelmutter M12x1,25 - ZSV02359A/F	1.000	ST
999	6.362-480.0	O-Ring 12,42x 1,78	1.000	ST

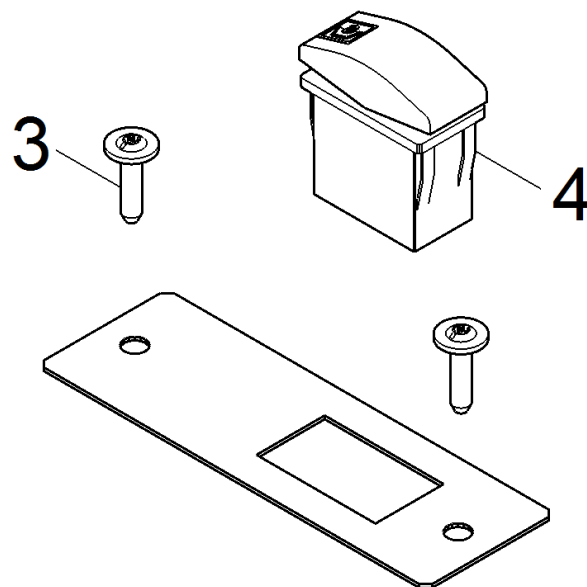
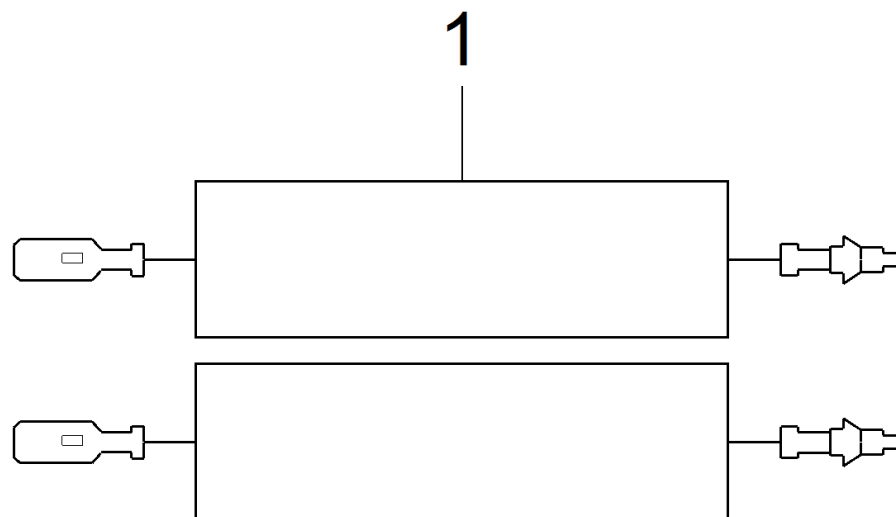

60 Set Taster (2.643-954.0)

POS	Artikelnr.	Beschreibung	Anzahl	Einheit
1	4.823-069.0	Adapterkabel Taster Hochentleerung	1.000	ST
3	6.303-125.0	Schraube 5x20-Sonder In6Rd+Spitze	2.000	ST
4	6.632-027.0	Taster	1.000	ST

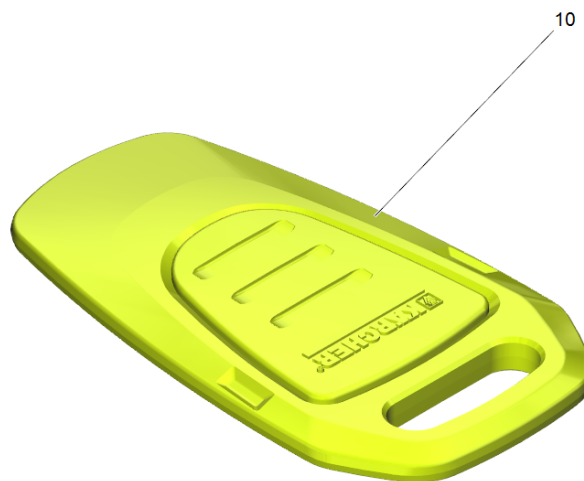

70 Set Schluessel gelb KIK KM (4.035-542.0)

POS	Artikelnr.	Beschreibung	Anzahl	Einheit
10	5.035-943.0	KIK-Schluessel gelb KM	5.000	ST

70 Hydraulikkreis KM 105/110

POS	Artikelnr.	Beschreibung	Anzahl	Einheit
0	5.972-230.0	ETL Hydraulikkreis KM 105/110	1.000	ST

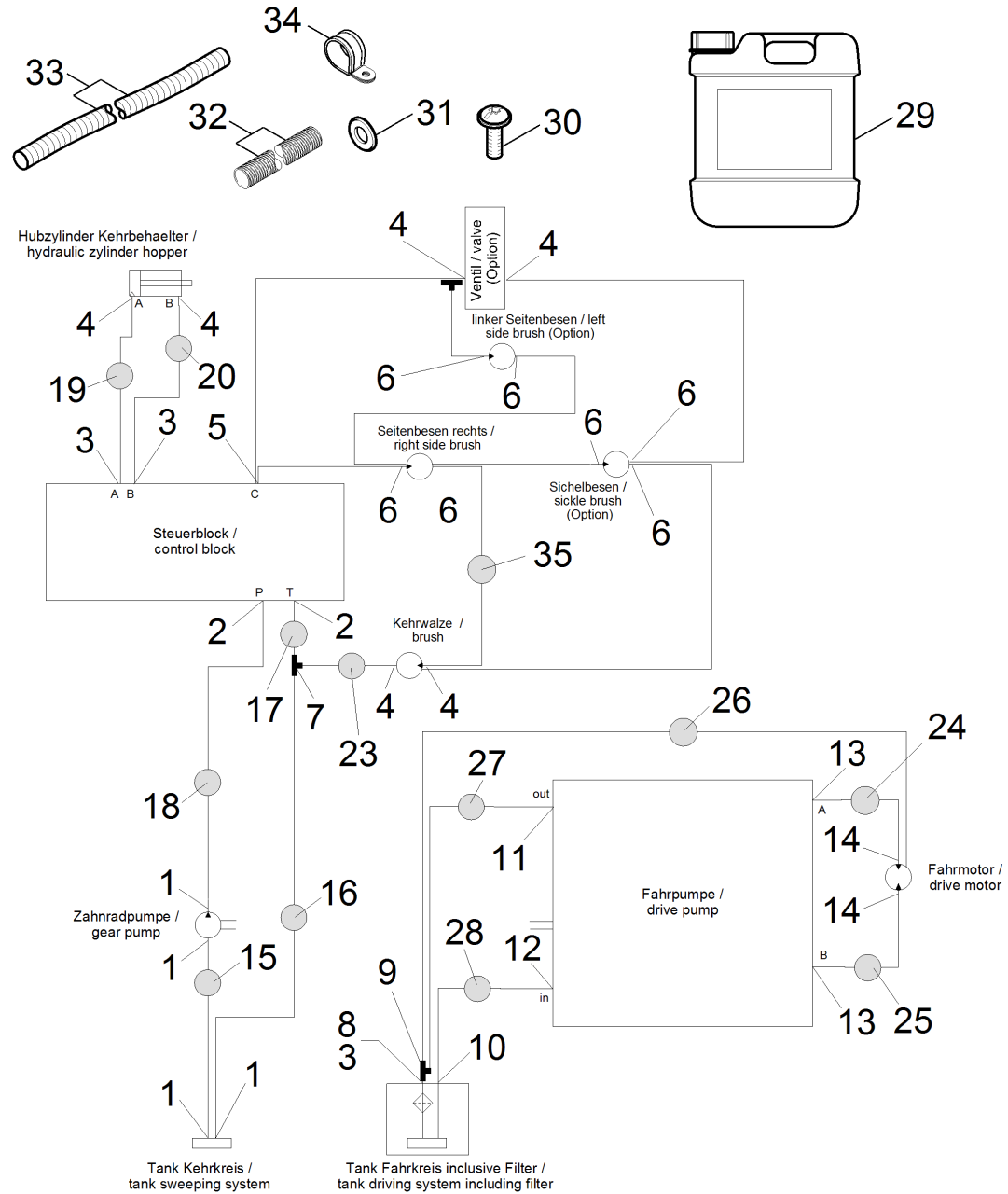

ETL Hydraulikkreis KM 105/110 (5.972-230.0)

POS	Artikelnr.	Beschreibung	Anzahl	Einheit	Fußnotentext
1	6.386-634.0	Verschraubung	4.000	ST	
2	6.386-635.0	Verschraubung XGE12LR1/4	2.000	ST	
3	6.386-163.0	Stutzen 8-L G1/4"	3.000	ST	
4	6.386-667.0	Verschraubung	4.000	ST	
5	6.386-635.0	Verschraubung XGE12LR1/4	1.000	ST	
6	6.386-712.0	Verschraubung	2.000	ST	
7	6.396-033.0	T-Verschraubung M14x1.5 - M18x1.5	1.000	ST	
8	6.396-039.0	Reduziernippel G3/4"-G1/4"	1.000	ST	
9	6.386-636.0	Verschraubung	1.000	ST	
10	6.386-673.0	Verschraubung XGE L 15 RB 3/4"	1.000	ST	
11	5.111-379.0	Reduzierung 9/16-18 UNF	1.000	ST	
12	6.386-641.0	Verschraubung XGE15L9/16-18 UNF	1.000	ST	
13	6.396-032.0	Verschraubung gerade M18x1.5- 3/4"	2.000	ST	
14	6.386-628.0	Verschraubung	2.000	ST	
15	6.396-013.0	Hydraulikschlauch DN12x1040	1.000	ST	
16	6.396-014.0	Hydraulikschlauch DN10x860	1.000	ST	
17	6.396-015.0	Hydraulikschlauch DN10x475	1.000	ST	
18	6.396-016.0	Hydraulikschlauch DN10x450	1.000	ST	
19	6.396-017.0	Hydraulikschlauch DN6x425	1.000	ST	
20	6.396-018.0	Hydraulikschlauch DN6x495	1.000	ST	
23	6.396-021.0	Hydraulikschlauch DN6x1080	1.000	ST	
24	6.396-022.0	Hydraulikschlauch DN10x1270	1.000	ST	
25	6.396-029.0	Hydraulikschlauch DN10x1275	1.000	ST	
26	6.396-038.0	Hydraulikschlauch DN6x2005	1.000	ST	
27	6.396-024.0	Hydraulikschlauch DN6x760	1.000	ST	
28	6.396-025.0	Hydraulikschlauch DN12x1080	1.000	ST	
29	4.070-987.0	Hydraulikoel Tellus 5 l	1.000	ST	
30	7.312-282.0	Scheibe 5 -A2 ISO 7093-1	1.000	ST	
31	7.303-086.0	Schraube 5x30 -10.9-R2R (K-In6Rd)	1.000	ST	
32	5.100-411.0	Spiralschlauch	1.000	M	ALS METERWARE BESTELLEN
33	6.391-475.0	Schutzschlauch	1.000	M	ALS METERWARE BESTELLEN
34	6.373-993.0	Schlauchschelle Gummi DN 20	1.000	ST	
35	6.396-020.0	Hydraulikschlauch DN6x1340	1.000	ST	

80 Antrieb Motor Diesel KM 105_1xx

POS	Artikelnr.	Beschreibung	Anzahl	Einheit
0	5.972-218.0	ETL Antrieb Diesel KM 105/1xx	1.000	ST

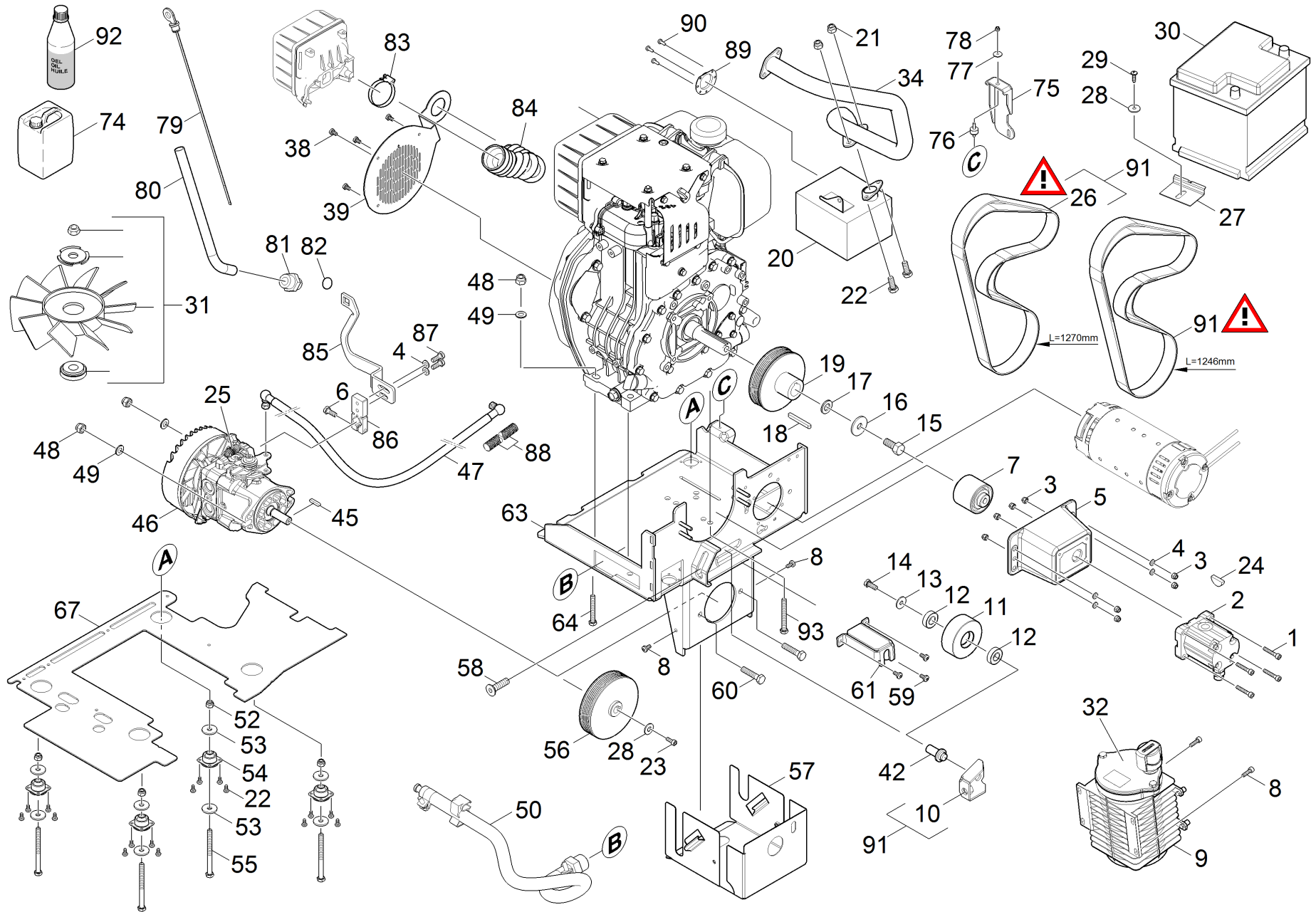

ETL Antrieb Diesel KM 105/1xx (5.972-218.0)

POS	Artikelnr.	Beschreibung	Anzahl	Einheit	Fußnotentext
1	7.306-025.0	Zyl.Schr. M 6x35-8.8-A2E ISO4762	8.000	ST	
2	6.503-037.0	Zahnradpumpe hydraulisch 2,6 ccm	1.000	ST	
3	7.311-512.0	6kt-Mutter M 6-8-A2E ISO 7040	9.000	ST	
4	7.312-003.0	Scheibe 6 -200HV-A3E ISO 7090	6.000	ST	
5	5.122-499.0	Halter Zahnrad Guss	1.000	ST	
7	6.463-000.0	Kupplung MOTOR-HY PUMPE	1.000	ST	
8	7.306-022.0	Zyl.Schr. M 6x20-8.8-A2E ISO4762	4.000	ST	
9	6.984-614.0	Oeltank Hydraulik Fahrtrieb	1.000	ST	
10	4.058-308.0	Riemenspanner Motorkonsole kpl.	1.000	ST	
11	5.625-533.0	Spannrolle	1.000	ST	
12	7.401-051.0	Kugellager 6002-2RS Waelzlagst DIN 625	2.000	ST	
13	7.312-277.0	Scheibe 8-200HV-A2E ISO7093-1	2.000	ST	
14	7.304-080.0	6kt-Schraube M8x20-12.9-Dacro ISO 4017	2.000	ST	
15	6.304-073.0	6kt-Schr. 7/16-20UNF-8.8-A2E ISO 4017	1.000	ST	
16	7.312-262.0	Scheibe 10 -100HV-A3E ISO 7094	1.000	ST	
17	7.312-008.0	Scheibe 12-200HV-A3E ISO 7090	1.000	ST	
18	6.905-999.0	Passfeder	1.000	ST	
19	5.625-530.0	Riemenscheibe Kurbelwelle	1.000	ST	
20	4.058-535.0	Dieselmotor Schalldaempfer	1.000	ST	
21	7.311-027.0	6kt-Mutter M 8-A4-70 ISO 7042	2.000	ST	
22	7.304-051.0	6kt-Schraube M 8x16-8.8-P2R EN 1665	2.000	ST	
23	7.304-169.0	Schraube M6x16 -10.9-A2K DIN 933	4.000	ST	
24	6.503-049.0	Passfeder Meta C001112	1.000	ST	
25	6.503-048.0	Feder Axialkolbenpumpe 51605	1.000	ST	
26	6.348-474.0	Keilrippenband 6PK 1270mm	1.000	ST	
27	5.047-460.0	Blechteil	1.000	ST	
28	7.312-260.0	Scheibe 6 -100HV-A3E ISO 7094	4.000	ST	
29	7.303-112.0	Schraube 6x20 -10.9-R2R (In6Rd)	2.000	ST	
30	7.654-001.0	Batterie 50Ah 12V	1.000	ST	
31	6.503-047.0	Luefter Set Axialkolbenpumpe 52014	1.000	ST	
32	6.984-622.0	Deckel Filter 1308963	1.000	ST	
34	4.058-399.0	Kruemmer Diesel L70	1.000	ST	
38	7.304-258.0	6kt-Schraube M 6x10-A4-70 ISO 4017	4.000	ST	

ETL Antrieb Diesel KM 105/1xx (5.972-218.0)

POS	Artikelnr.	Beschreibung	Anzahl	Einheit	Fußnotentext
39	5.095-576.0	Schutzblech Kuehlluft Diesel L70	1.000	ST	
42	5.111-281.0	Bolzen Riemenspanner Motorkonsole	1.000	ST	
45	6.318-009.0	Passfeder 5,08 x 5,0 x 25	1.000	ST	
46	6.503-045.0	Axialkolbenpumpe PG-Serie	1.000	ST	
47	6.431-301.0	Bowdenzug Push-Pull	1.000	ST	
48	7.311-511.0	6kt-Mutter M10-8-A2E ISO 7040	6.000	ST	
49	7.312-005.0	Scheibe 10-200HV-A3E ISO 7090	6.000	ST	
50	4.423-045.0	Oel Ablass KM 105/1xx R D	1.000	ST	
52	7.311-510.0	6kt-Mutter M 8-8-A2E ISO 7040	4.000	ST	
53	7.312-261.0	Scheibe 8 -100HV-A3E ISO 7094	12.000	ST	
54	6.339-264.0	Gummipuffer AT00	4.000	ST	
55	7.304-454.0	6kt-Schraube M 8x100-8.8-A2E ISO 4017	4.000	ST	
56	5.625-532.0	Riemenscheibe Axialkolbenpumpe	1.000	ST	
57	4.058-474.0	Luftfuehrung	1.000	ST	
58	7.305-122.0	Senkschraube M12x70 -A4-70 DIN 7991	1.000	ST	
59	7.306-031.0	Schraube M 6x16-A2-70 DIN 7984	3.000	ST	
60	7.304-426.0	6kt-Schraube M10x45-8.8-A3E ISO 4017	6.000	ST	
61	5.095-457.0	Blechteil Halter Push Pull	1.000	ST	
62	6.491-007.0	Dieselmotor Yanmar L70N	1.000	ST	
63	4.058-286.0	Motorkonsole kpl.	1.000	ST	
64	7.304-426.0	6kt-Schraube M10x45-8.8-A3E ISO 4017	3.000	ST	
67	5.033-871.0	Staubschutz Benzin links	1.000	ST	
74	4.070-986.0	Hydraulikoel Renolin 5 l	1.000	ST	
74	4.070-979.0	Hydraulikoel Renolin 1,5 l	1.000	ST	
75	5.095-520.0	Blechteil Halter Auspuff EX27	1.000	ST	
76	6.339-241.0	Gummipuffer 2xM6 D20 H12	1.000	ST	
77	7.312-260.0	Scheibe 6 -100HV-A3E ISO 7094	1.000	ST	
78	7.311-512.0	6kt-Mutter M 6-8-A2E ISO 7040	1.000	ST	
79	6.492-008.0	Oelmesstab KM105/1XX R D	1.000	ST	
80	6.396-044.0	Rohr Verlaengerung Oelmesstab	1.000	ST	
81	5.396-000.0	Verschraubung gerade M22x2.5 / M26x1.5	1.000	ST	
82	6.362-442.0	O-Ring 18,0 X 2,0-FPM 70	1.000	ST	
83	6.902-167.0	Schlauchschelle 40-60 mm	1.000	ST	

ETL Antrieb Diesel KM 105/1xx (5.972-218.0)

POS	Artikelnr.	Beschreibung	Anzahl	Einheit	Fußnotentext
84	6.437-004.0	Faltenbalg D1=35 D2=48 L1=200	1.000	ST	
85	5.095-720.0	Blechteil Anbindung Bypass	1.000	ST	
86	5.095-721.0	Blechteil Verbindung Bypass	1.000	ST	
87	7.304-169.0	Schraube M6x16 -10.9-A2K DIN 933	2.000	ST	
88	5.100-411.0	Spiralschlauch	1.000	M	ALS METERWARE BESTELLEN
89	6.492-060.0	Sieb 277-37203-H1	1.000	ST	
90	7.306-076.0	Schraube M5x12 -8.8-ZNBHL ISO 14583	3.000	ST	
91	2.643-445.0	Umbau Set 6 PK 1270mm	1.000	ST	
92	6.288-050.0	Motorenoel 1L	1.000	ST	
93	7.304-287.0	6kt-Schraube M10x50-8.8-GE3A/VL ISO 4017	1.000	ST	

2 Zahnradpumpe hydraulisch 2,6 ccm (6.503-037.0)

POS	Artikelnr.	Beschreibung	Anzahl	Einheit
999	6.503-049.0	Passfeder Meta C001112	1.000	ST

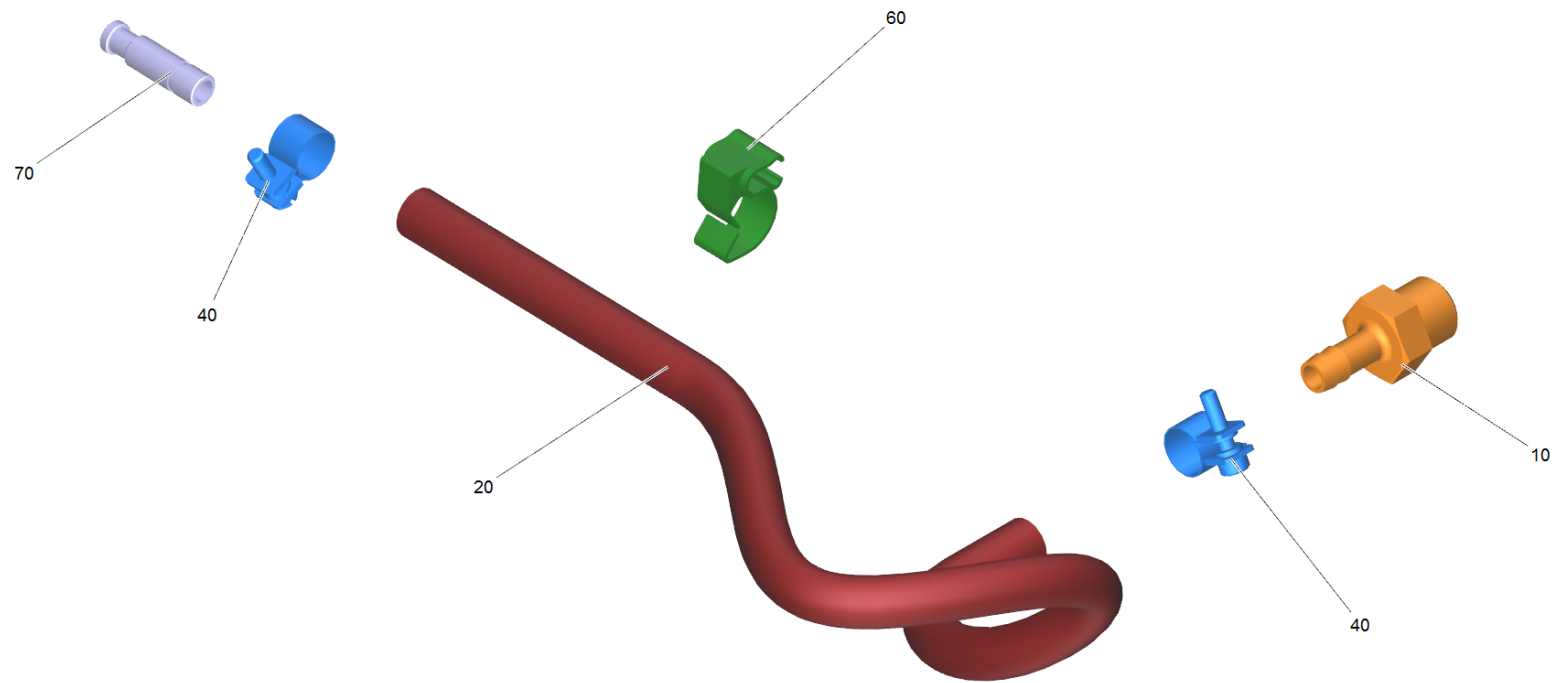

50 Oel Ablass KM 105/1xx R D (4.423-045.0)

POS	Artikelnr.	Beschreibung	Anzahl	Einheit	Fußnotentext
10	5.423-000.0	Schlauchtuelle Oel Ablass KM 105/1xx R D	1.000	ST	
20	6.389-610.0	Schlauch	1.000	M	ALS METERWARE BESTELLEN
40	6.388-537.0	Schlauchschelle	2.000	ST	
60	6.650-291.0	Kabelclip 4 mm	1.000	ST	
70	6.437-012.0	Bolzen	1.000	ST	

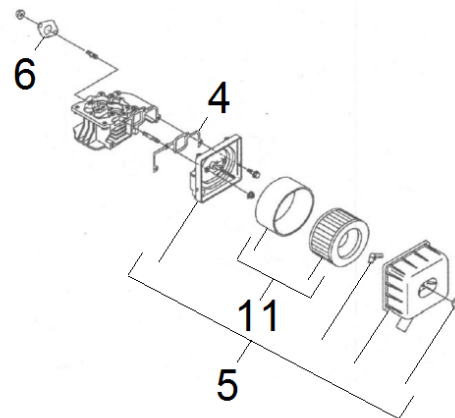
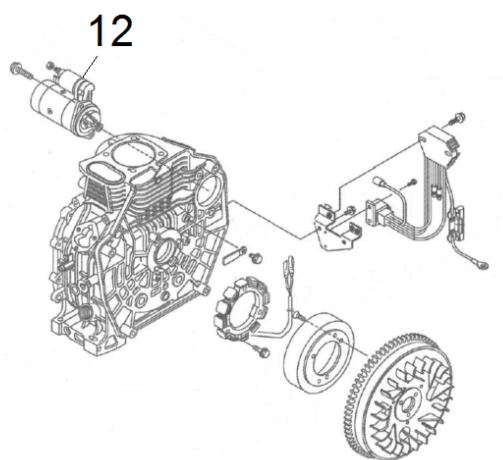
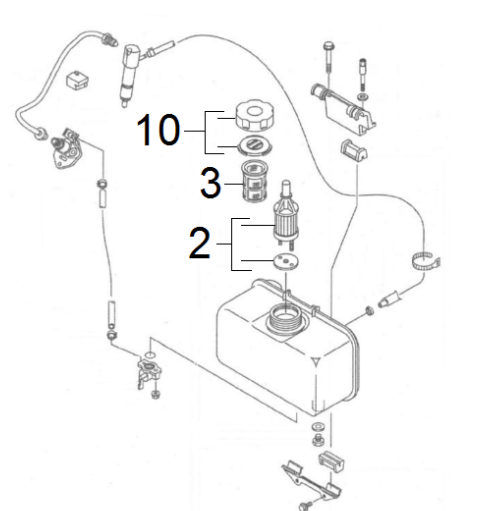
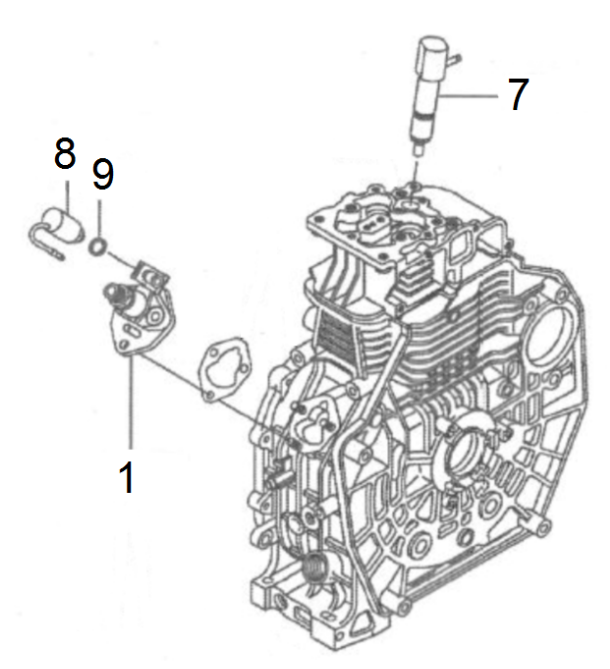

62 Dieselmotor Yanmar L70N (6.491-007.0)

POS	Artikelnr.	Beschreibung	Anzahl	Einheit
1	6.491-018.0	Pumpe Kraftstoff Injektor	1.000	ST
2	6.491-012.0	Filter kpl.	1.000	ST
3	6.491-994.0	Kraftstofffilter	1.000	ST
4	6.491-014.0	Dichtung Luftfilter	1.000	ST
5	6.491-015.0	Luftfilter kpl.	1.000	ST
6	6.491-016.0	Dichtung Schalldaempfer	1.000	ST
7	6.491-017.0	Kraftstoff Injektor	1.000	ST
8	6.491-011.0	Ventil kpl.	1.000	ST
9	6.491-019.0	Dichtung Ventil 10x1,2	1.000	ST
10	6.491-020.0	Deckel Kraftstofftank	1.000	ST
11	6.491-958.0	Luftfiltereinsatz	1.000	ST
12	6.491-273.0	Anlasser	1.000	ST

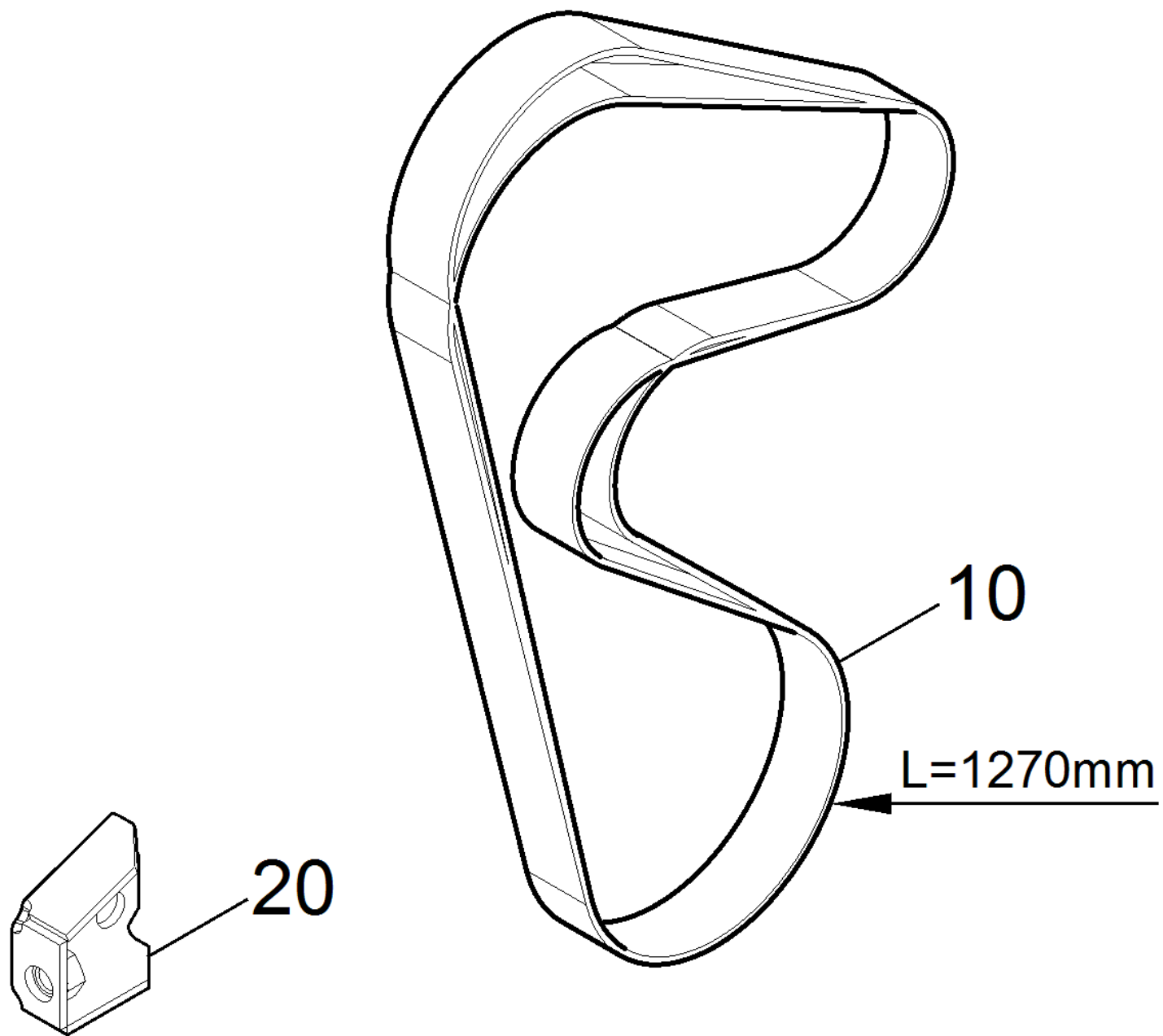

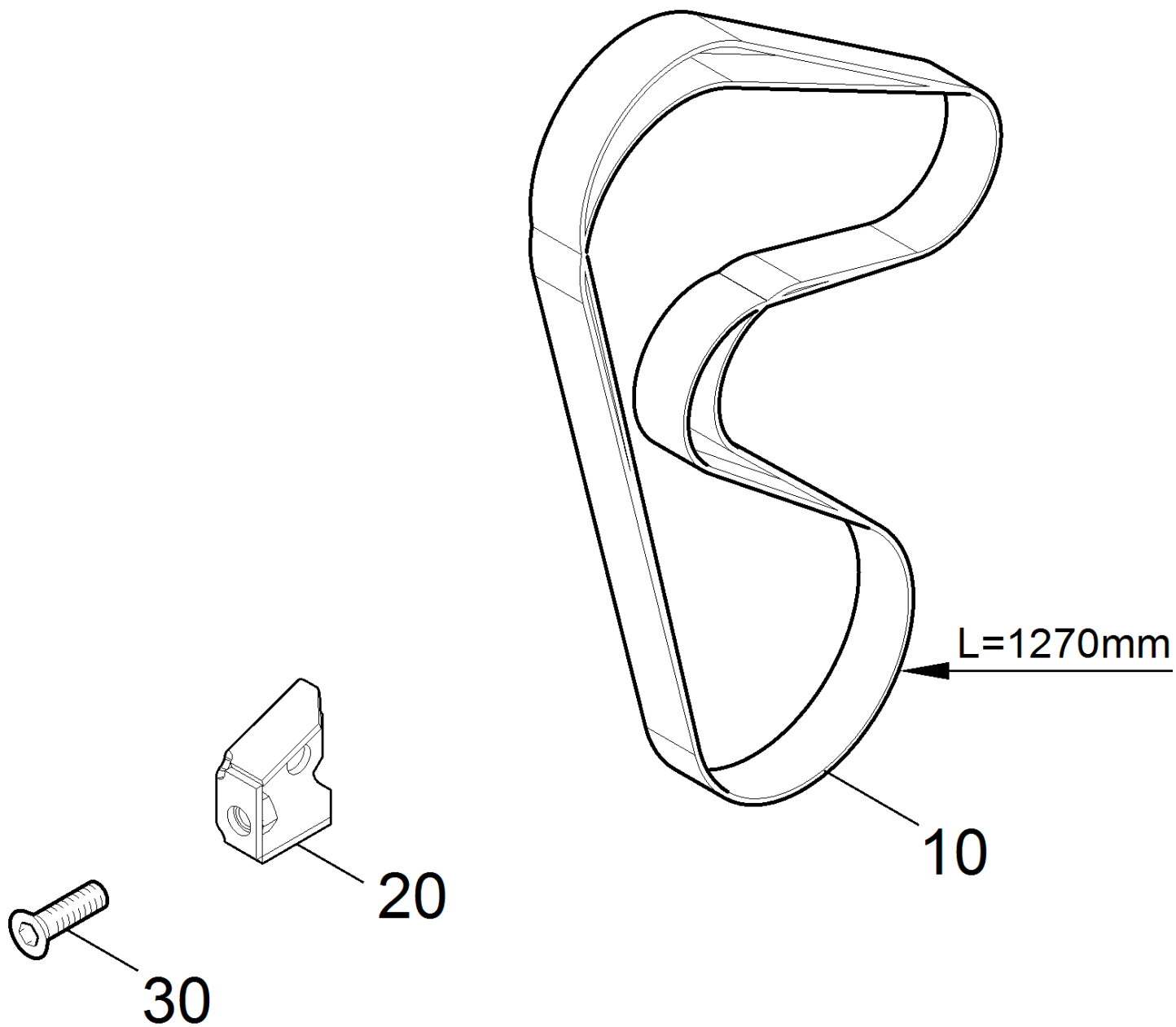

91 Umbau Set 6 PK 1270mm (2.643-445.0)

POS	Artikelnr.	Beschreibung	Anzahl	Einheit
10	6.348-474.0	Keilrippenband 6PK 1270mm	1.000	ST
20	4.058-308.0	Riemenspanner Motorkonsole kpl.	1.000	ST
30	7.305-122.0	Senkschraube M12x70 -A4-70 DIN 7991	1.000	ST

90 Haube links Diesel KM 105_1xx

POS	Artikelnr.	Beschreibung	Anzahl	Einheit
0	5.972-222.0	ETL Haube links Diesel KM 105/1xx	1.000	ST

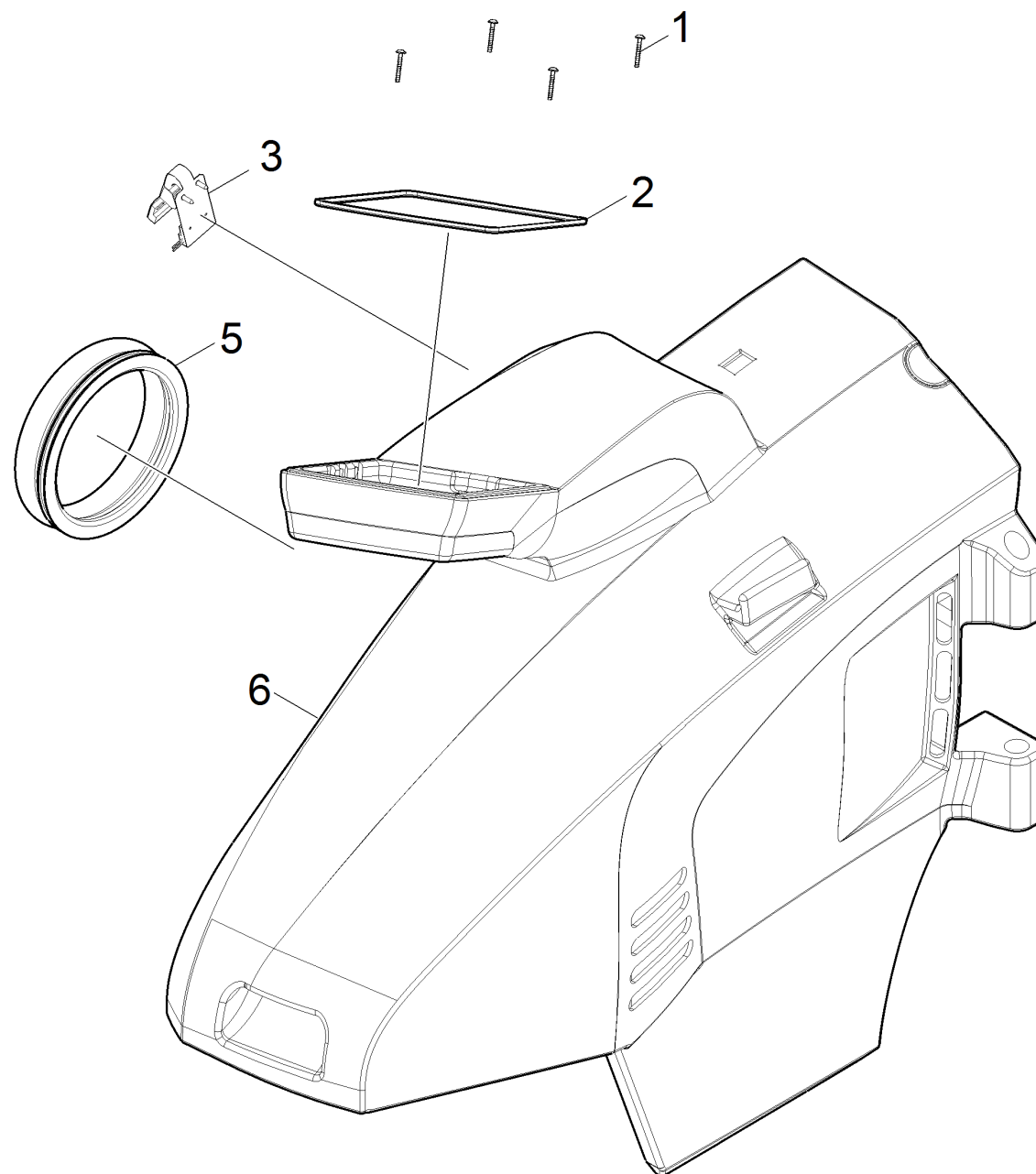

ETL Haube links Diesel KM 105/1xx (5.972-222.0)

POS	Artikelnr.	Beschreibung	Anzahl	Einheit	Fußnotentext
1	7.303-086.0	Schraube 5x30 -10.9-R2R (K-In6Rd)	4.000	ST	
2	5.035-161.0	Formdichtung Bedienfeld	1.000	ST	
3	2.643-844.0	Set Federblech Reedkontakt	1.000	ST	
5	6.366-059.0	Dichtprofil Kantenschutz	1.000	M	ALS METERWARE BESTELLEN
6	5.033-878.0	Haube links Diesel KM105/1xx	1.000	ST	

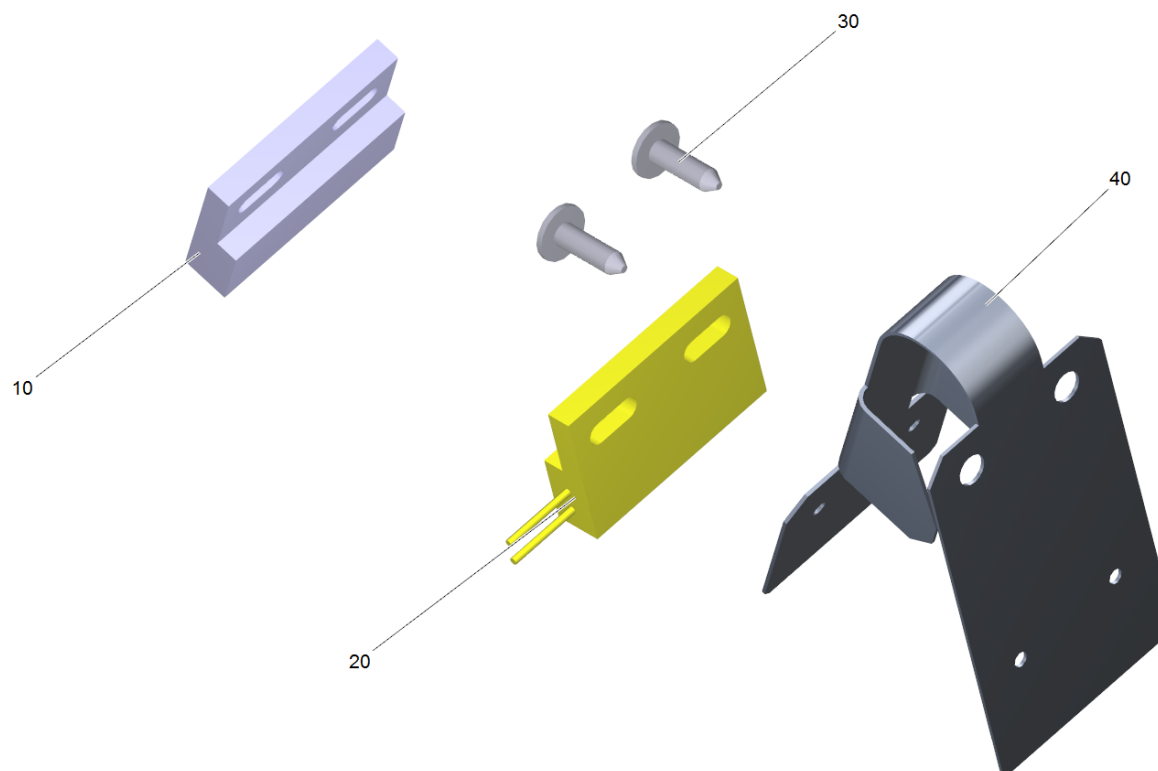

3 Set Federblech Reedkontakt (2.643-844.0)

POS	Artikelnr.	Beschreibung	Anzahl	Einheit
10	6.632-515.0	Magnet in Gehaeuse	1.000	ST
20	6.632-541.0	Reedsensor 650 mm	1.000	ST
30	7.303-242.0	Schraube 3x10 -A2-70 (IN6RD)	2.000	ST
40	5.096-532.0	Federblech Reedkontakt	1.000	ST

20 Reedsensor 650 mm (6.632-541.0)

POS	Artikelnr.	Beschreibung	Anzahl	Einheit
10	6.422-055.0	Steckergehaeuse 2-Wege Superseal 1.5	1.000	ST

10 Steckergehaeuse 2-Wege Superseal 1.5 (6.422-055.0)

POS	Artikelnr.	Beschreibung	Anzahl	Einheit
10	6.641-332.0	Kabel 0,5 ² für AMP Super Seal 1,5 Male	1.000	ST
20	6.641-334.0	Kabel 1,0 ² für AMP Super Seal 1,5 Male	1.000	ST

200 Seitenbesen rechts + Kehrsichel

POS	Beschreibung	Anzahl	Einheit
10	Kehrsichelsystem rechts hydraulisch	1.000	ST
20	Hydraulikkreis Seitenbesen rechts KM 105	1.000	ST
30	Hydraulikkreis Kehrsichelsystem KM 105_1	1.000	ST

10 Kehrsichelsystem rechts hydraulisch

POS	Artikelnr.	Beschreibung	Anzahl	Einheit
10	5.095-324.0	Blechteil Sensor	1.000	ST
20	6.330-459.0	Potentiometer Wellen Sensor KM Medium	1.000	ST
30		Seitenbesen rechts hydraulisch	1.000	ST
40		Seitenbesen hinten hydraulisch	1.000	ST
50	7.306-107.0	Zylinderschraube M4x16-A4-70 ISO 4762	4.000	ST
60	7.304-051.0	6kt-Schraube M 8x16-8.8-P2R EN 1665	4.000	ST

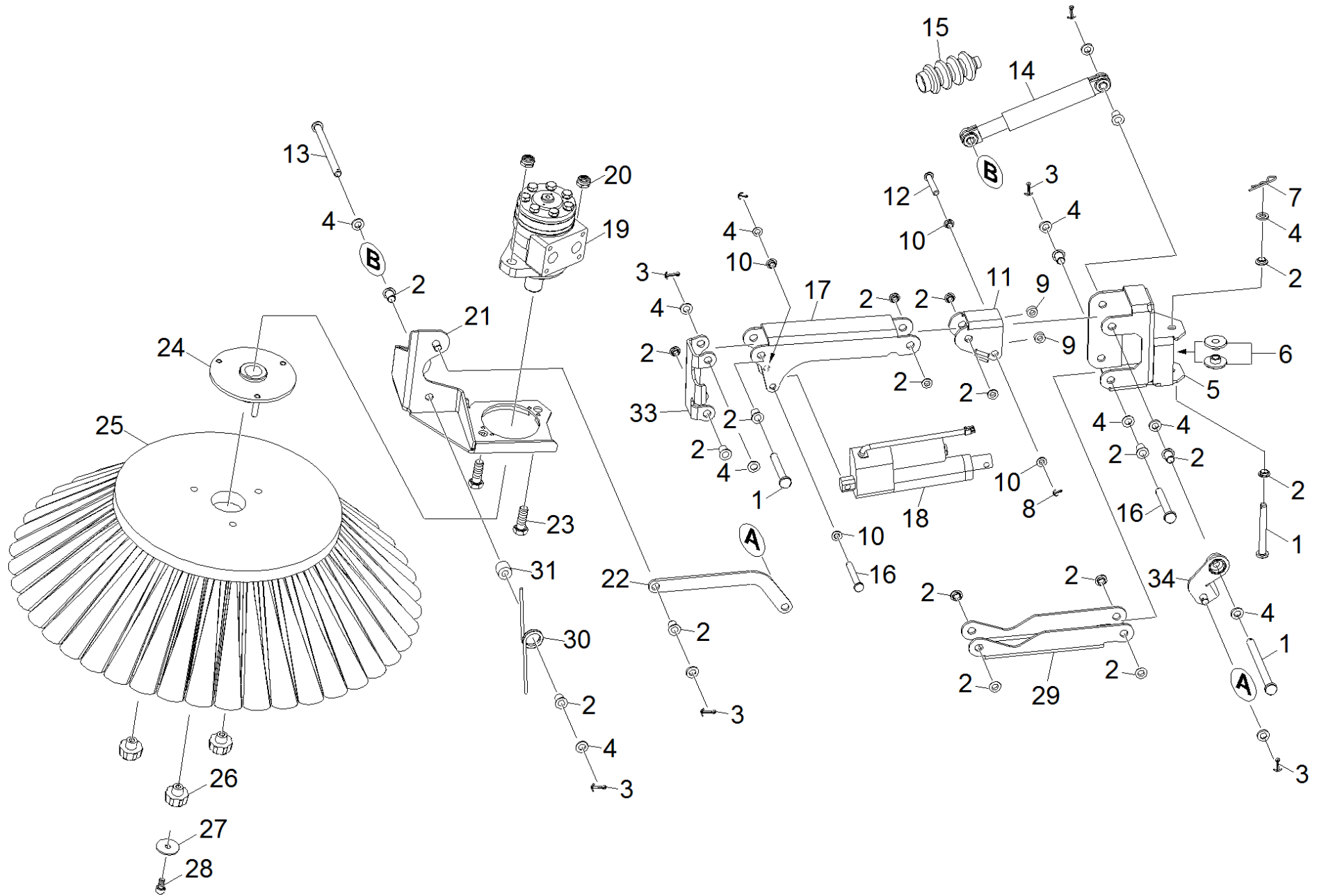

30 Seitenbesen rechts hydraulisch

POS	Artikelnr.	Beschreibung	Anzahl	Einheit
1	7.316-044.0	Bolzen B 10x85 -St-A2E ISO 2341	4.000	ST
2	6.403-074.0	Gleitlager 10mm	20.000	ST
3	7.316-346.0	Splint 3,2x18 -St-A2E ISO 1234	5.000	ST
4	7.312-005.0	Scheibe 10-200HV-A3E ISO 7090	5.000	ST
5	4.058-364.0	Halter kpl. rechts SB	1.000	ST
6	5.112-069.0	Buchse	2.000	ST
7	6.313-002.0	Federstecker 2,0	1.000	ST
8	7.316-336.0	Splint 2x16-St-A2E ISO 1234	2.000	ST
9	5.111-205.0	Huelse	3.000	ST
10	6.437-485.0	Lagerbuchse	4.000	ST
11	5.095-328.0	Hebel Umlenkung rechts	1.000	ST
12	7.316-047.0	Bolzen B8x50 -St-A2E ISO 2341	1.000	ST
13	7.316-215.0	Bolzen B10,0x100-ST-A2E ISO 2341	1.000	ST
14	6.437-659.0	Stosssdaempfer 120N l=185mm	1.000	ST
15	6.437-662.0	Faltenbalg D14/26	1.000	ST
16	7.316-043.0	Bolzen B 8x65 -St-A2E ISO 2341	1.000	ST
17	5.095-327.0	Profil Seitenbesen oben	1.000	ST
18	6.504-114.0	Hubzylinder Verstellung Seitenbesen	1.000	ST
19	6.503-040.0	Hydraulikmotor OZ100	1.000	ST
20	7.311-515.0	6kt-Mutter M12-8-A2E ISO 7040	2.000	ST
21	4.058-312.0	Motorhalter hydraulisch rechts	1.000	ST
22	5.095-347.0	Blechteil Schubstange	1.000	ST
23	7.304-441.0	6kt-Schraube M12x35-8.8-A3E ISO 4017	2.000	ST
24	4.120-246.0	Nabe hydraulisch	1.000	ST
25	6.966-063.0	Seitenbesen Standard PET	1.000	ST
25	6.966-065.0	Seitenbesen weich	1.000	ST
25	6.906-705.0	Seitenbesen D 600	1.000	ST
26	6.310-066.0	Sterngriff M 8	3.000	ST
27	5.062-199.0	Scheibe D 34	1.000	ST
28	7.306-040.0	Zyl.Schr. M8x16 -8.8-A2E ISO4762	1.000	ST
29	5.095-233.0	Profil Seitenbesen unten	1.000	ST
30	6.330-463.0	Schenkelfeder T-19520 R	1.000	ST
31	5.640-462.0	Distanzhuelse	1.000	ST

30 Seitenbesen rechts hydraulisch

POS	Artikelnr.	Beschreibung	Anzahl	Einheit
32	5.111-365.0	Lagerbolzen	1.000	ST
33	5.095-326.0	Blechteil Verbindung Stuetze	1.000	ST
34	4.058-363.0	Hebel kpl. rechts	1.000	ST

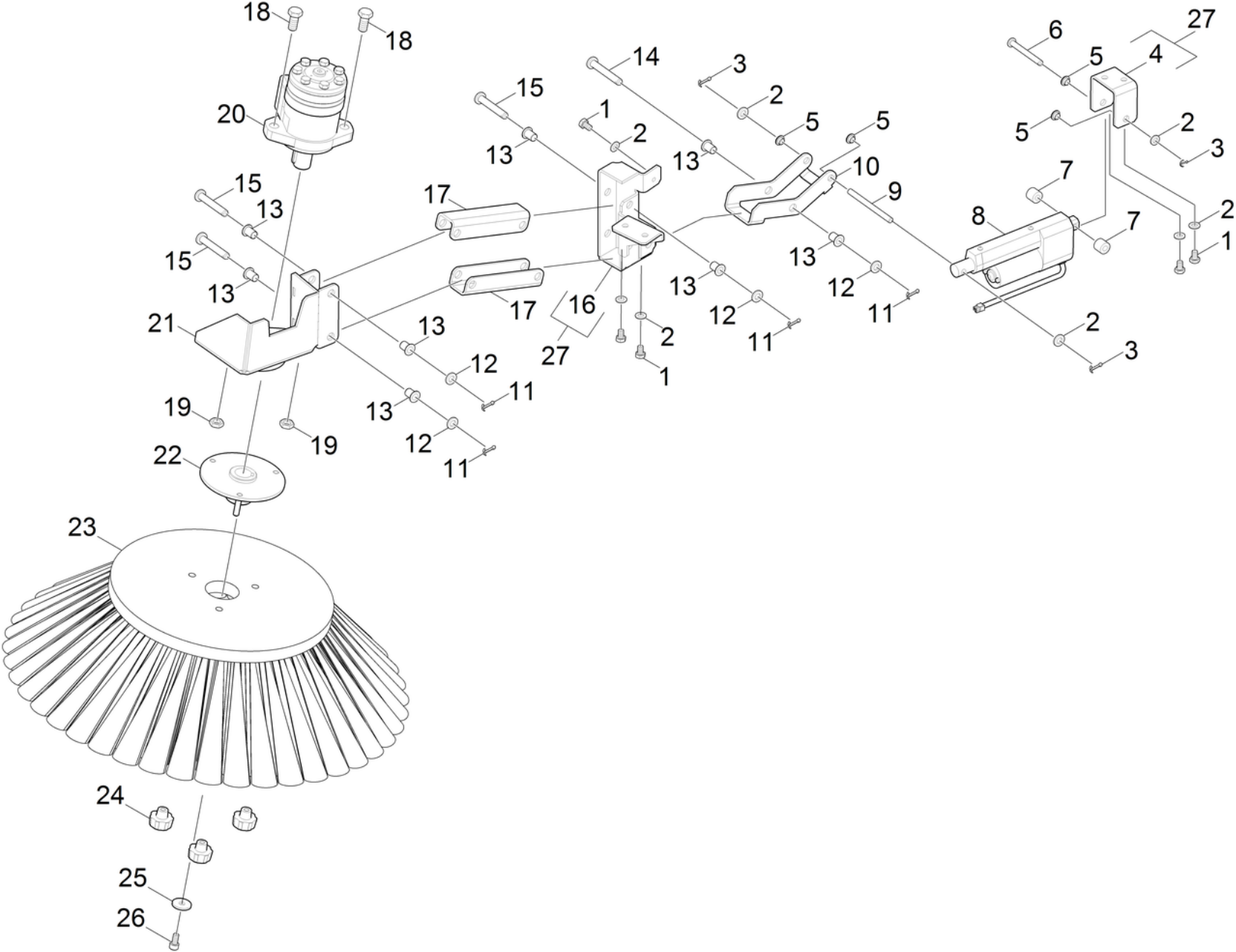

40 Seitenbesen hinten hydraulisch

POS	Artikelnr.	Beschreibung	Anzahl	Einheit
1	7.304-394.0	6kt-Schraube M8x12 -8.8-A2E ISO 4017	5.000	ST
2	7.312-004.0	Scheibe 8 -200HV-A3E ISO 7090	8.000	ST
3	7.316-336.0	Splint 2x16-St-A2E ISO 1234	3.000	ST
4	5.095-421.0	Halter Anhebung	1.000	ST
5	6.437-485.0	Lagerbuchse	4.000	ST
6	7.316-043.0	Bolzen B 8x65 -St-A2E ISO 2341	1.000	ST
7	5.112-618.0	Buchse D18 x 15	2.000	ST
8	6.504-114.0	Hubzylinder Verstellung Seitenbesen	1.000	ST
9	5.111-370.0	Lagerbolzen 8x92	1.000	ST
10	5.095-420.0	Hebel Anhebung	1.000	ST
11	7.316-346.0	Splint 3,2x18 -St-A2E ISO 1234	4.000	ST
12	7.312-005.0	Scheibe 10-200HV-A3E ISO 7090	4.000	ST
13	6.403-074.0	Gleitlager 10mm	20.000	ST
14	7.316-045.0	Bolzen B 10x75 -St-A2E ISO 2341	1.000	ST
15	7.316-226.0	Bolzen B-10x60-St-A2E ISO 2341	4.000	ST
16	4.058-561.0	Halter Seitenbesen hinten	1.000	ST
17	5.095-272.0	Profil Seitenbesen hinten	2.000	ST
18	7.304-441.0	6kt-Schraube M12x35-8.8-A3E ISO 4017	2.000	ST
19	7.311-515.0	6kt-Mutter M12-8-A2E ISO 7040	2.000	ST
20	6.503-040.0	Hydraulikmotor OZ100	1.000	ST
21	4.058-313.0	Motorhalter hydraulisch hinten	1.000	ST
22	4.120-246.0	Nabe hydraulisch	1.000	ST
23	6.966-063.0	Seitenbesen Standard PET	1.000	ST
24	6.310-066.0	Sterngriff M 8	3.000	ST
25	7.312-268.0	Scheibe 8 -A2 ISO 7094	1.000	ST
26	7.306-040.0	Zyl.Schr. M8x16 -8.8-A2E ISO4762	1.000	ST
27	2.643-774.0	Set Halter Seitenbesen	1.000	ST

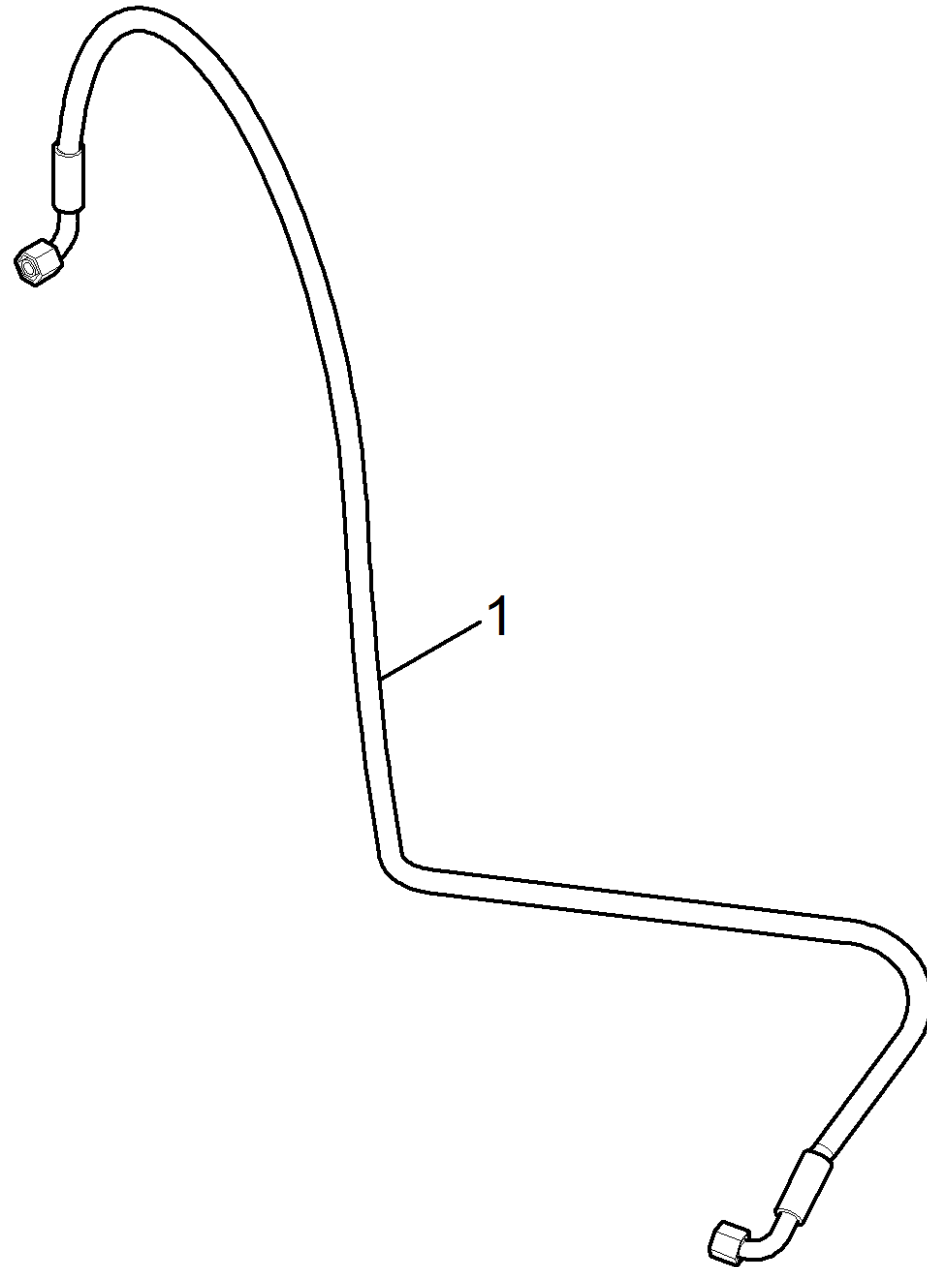

20 Hydraulikkreis Seitenbesen rechts KM 105

POS	Artikelnr.	Beschreibung	Anzahl	Einheit
10	6.396-019.0	Hydraulikschlauch DN6x1360	1.000	ST

30 Hydraulikkreis Kehrsichelsystem KM 105_1

POS	Artikelnr.	Beschreibung	Anzahl	Einheit
10	6.396-026.0	Hydraulikschlauch DN6x1130	1.000	ST
20	6.396-027.0	Hydraulikschlauch DN6x530	1.000	ST
30	6.386-712.0	Verschraubung	2.000	ST

290 Sitz Standard kpl.

POS	Artikelnr.	Beschreibung	Anzahl	Einheit
0	5.972-234.0	ETL Sitz Standard KM Medium	1.000	ST

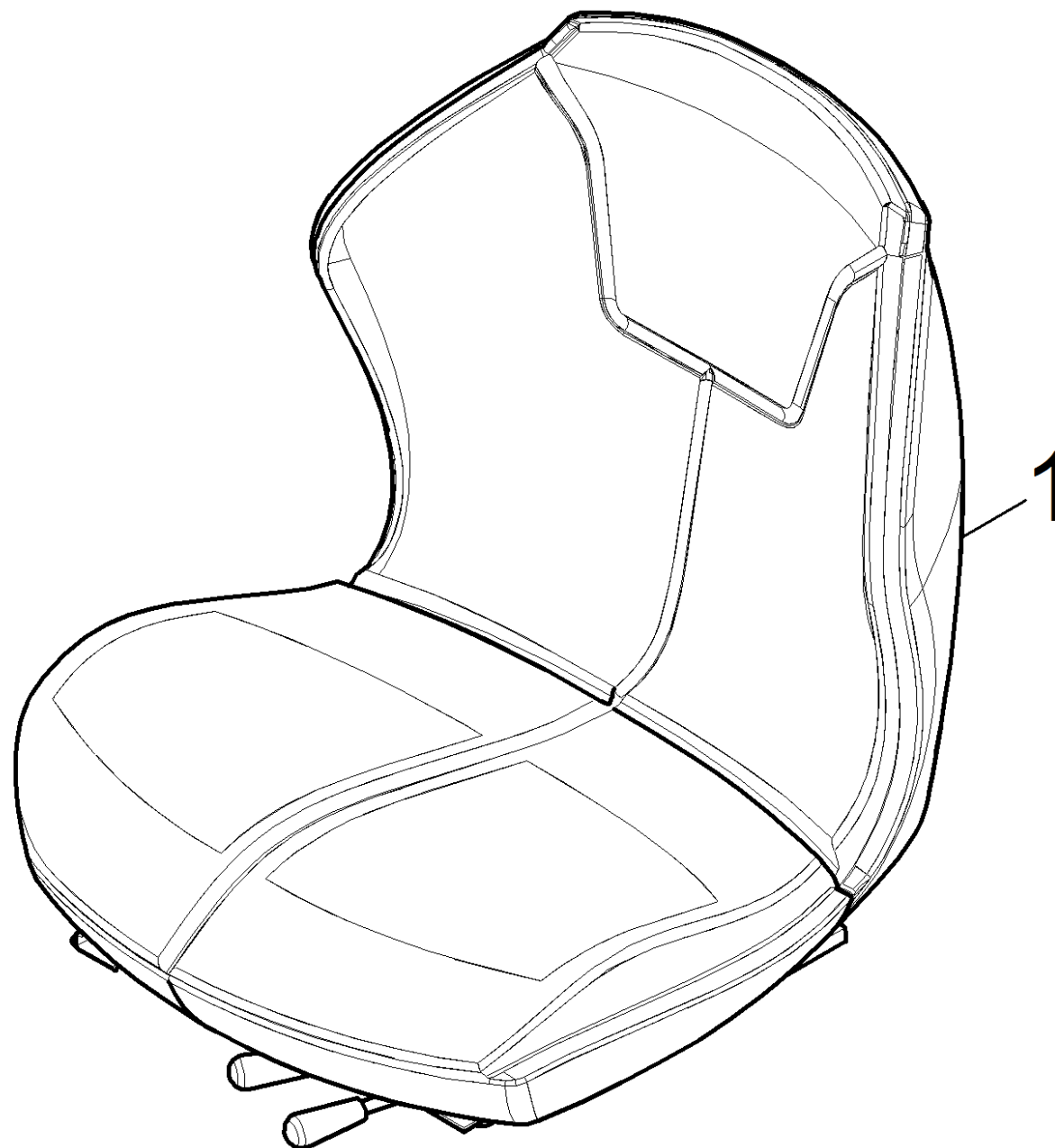

ETL Sitz Standard KM Medium (5.972-234.0)

POS	Artikelnr.	Beschreibung	Anzahl	Einheit
1	6.394-729.0	Sitz COBO PS48	1.000	ST



1 Sitz COBO PS48 (6.394-729.0)

POS	Artikelnr.	Beschreibung	Anzahl	Einheit
10	6.394-959.0	Schalter Sitz Ersatz	1.000	ST

320 Radsatz Standard Verbrenner

POS	Artikelnr.	Beschreibung	Anzahl	Einheit
0	5.972-231.0	ETL Radsatz Standard KM Medium	1.000	ST

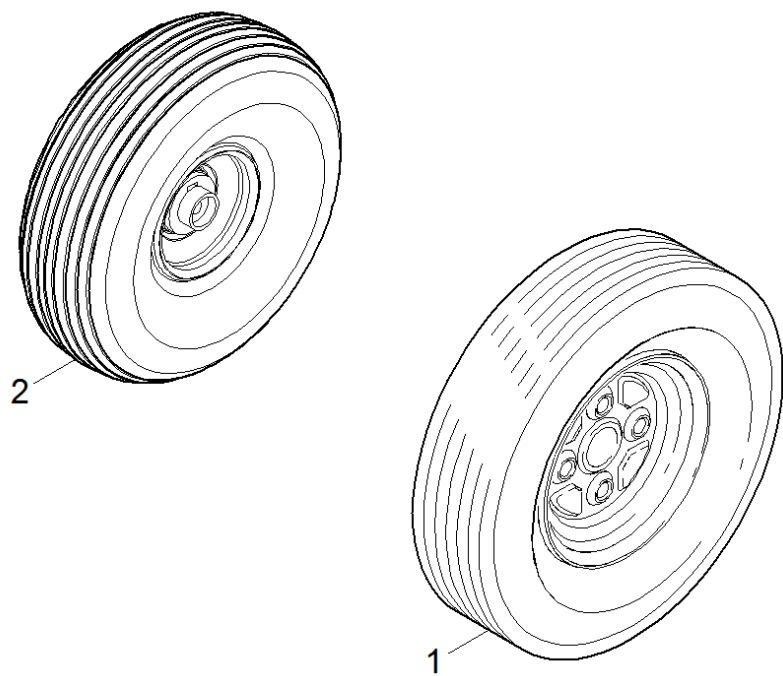

ETL Radsatz Standard KM Medium (5.972-231.0)

POS	Artikelnr.	Beschreibung	Anzahl	Einheit
1	6.435-833.0	Rad kpl.	2.000	ST
2	6.435-002.0	Vorderrad	1.000	ST