

## **Ersatzteilliste**

(1.161-311.0) B 90 R DOSE Bp Pack

## Inhaltsverzeichnis

---

B 90 R DOSE Bp Pack (1.161-311.0)	3
20 ETL B 90 R DOSE Bp Pack (5.971-847.0)	4
10 Tank	5
11 Frischwassertank	6
12 Schmutzwassertank	9
20 Fahrwerk	11
21 Pedal	12
23 Anbausatz (2.641-718.0)	15
22 Rammschutz	16
23 Einzelteile	18
30 Lenkung	20
19 Fahrmotor (6.613-315.0)	22
9004 Ersatzteil Set Lager (4.641-045.0)	24
38 Fahrmotor 600W (6.613-206.3)	25
40 Sitz	27
50 Batterie	29
5 Polklemme 1-fach (6.643-948.0)	31
8 Antriebsbatterie wartungsfrei 170Ah (6.654-242.0)	33
60 Saugbalkenanhebung	35
70 Bedienpult	37
2 Schlüsselschalter (6.630-106.0)	39
80 RM Dosierung	41

B 90 R DOSE Bp Pack (1.161-311.0)

---

<b>POS</b>	<b>Artikelnr.</b>	<b>Beschreibung</b>	<b>Anzahl</b>	<b>Einheit</b>
10		Doku B 90 R	1.000	ST
20	5.971-847.0	ETL B 90 R DOSE Bp Pack	1.000	ST

20 ETL B 90 R DOSE Bp Pack (5.971-847.0)

---

<b>POS</b>	<b>Beschreibung</b>	<b>Anzahl</b>	<b>Einheit</b>
10	Tank	1.000	ST
20	Fahrwerk	1.000	ST
30	Lenkung	1.000	ST
40	Sitz	1.000	ST
50	Batterie	1.000	ST
60	Saugbalkenanhebung	1.000	ST
70	Bedienpult	1.000	ST
80	RM Dosierung	1.000	ST

## 10 Tank

---

<b>POS</b>	<b>Beschreibung</b>	<b>Anzahl</b>	<b>Einheit</b>
11	Frischwassertank	1.000	ST
12	Schmutzwassertank	1.000	ST

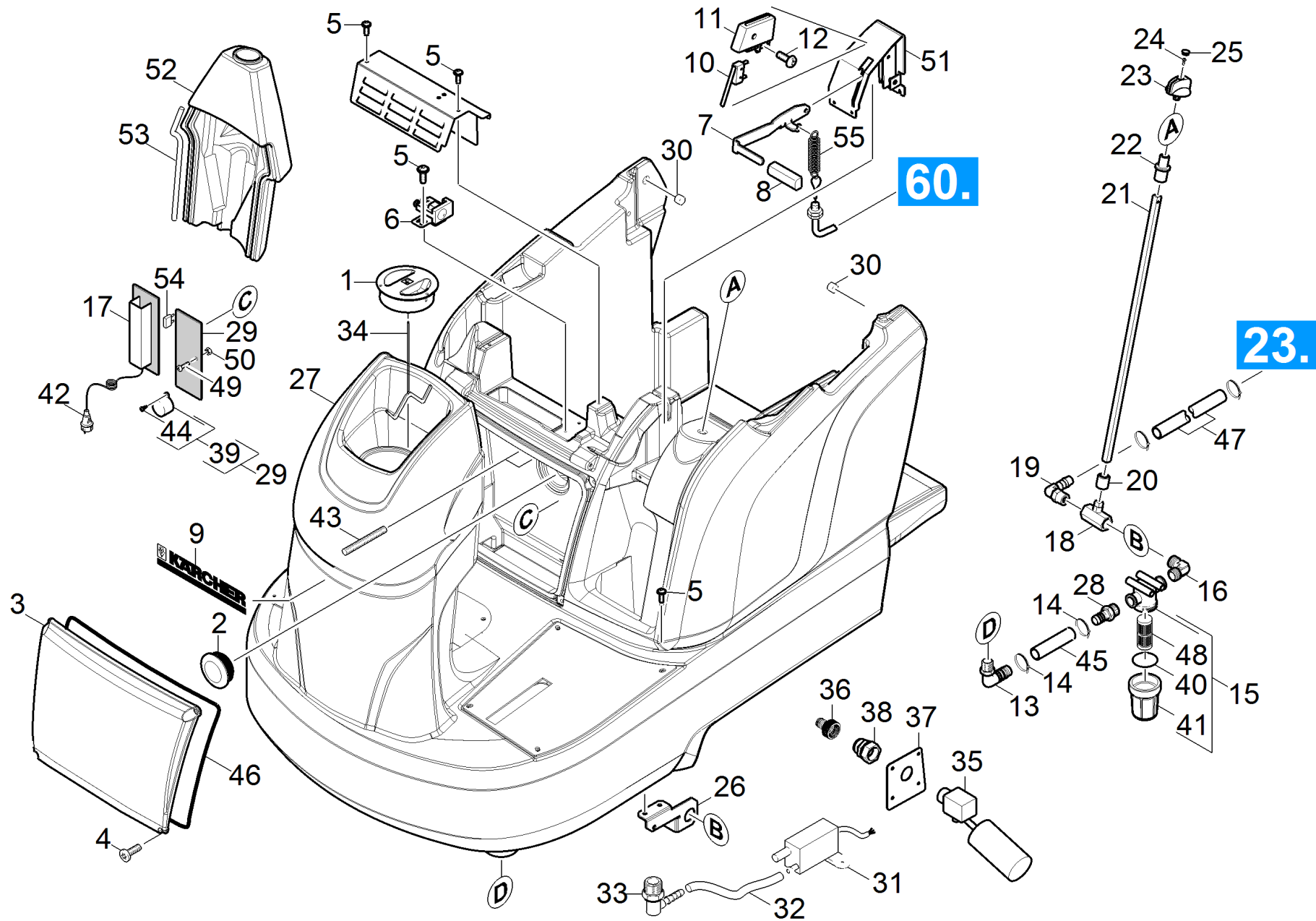

## 11 Frischwassertank

POS	Artikelnr.	Beschreibung	Anzahl	Einheit	Fußnotentext
1	5.064-389.0	Deckel	1.000	ST	
2	5.132-124.0	Stopfen	1.000	ST	
3	5.064-259.0	Abdeckung Elektronik	1.000	ST	
4	7.306-089.0	Schraube M6x12 -8.8-R2R (In6Rd)	4.000	ST	
5	7.303-107.0	Schraube 5x16 -10.9-P2R (K-In6Rd)	10.000	ST	
6	6.633-389.0	Relais	1.000	ST	
7	5.062-281.0	Blech Griff	1.000	ST	
8	5.321-457.0	Griff	1.000	ST	
9	5.383-754.0	Schild	1.000	ST	
10	6.630-398.0	Mikroschalter	1.000	ST	
11	5.060-998.0	Gehaeuse Mikroschalter	1.000	ST	
12	7.303-129.0	Schraube 4x16 -10.9-R2R (K-In6Rd)	1.000	ST	
13	5.443-481.0	Winkeltuelle	1.000	ST	
14	6.641-464.0	Kabelbinder	2.000	ST	
15	6.907-203.3	Filter Frischwasser	1.000	ST	
16	6.391-717.0	Winkelverschraubung 1/2"	1.000	ST	
17	6.654-278.0	Ladegeraet on board 24V 35A	1.000	ST	
18	6.413-586.0	Kugelhahn ohne Griff	1.000	ST	
19	6.390-002.0	Winkeltuelle	1.000	ST	
20	5.470-033.0	Kupplung	1.000	ST	
21	5.107-281.0	Stange	1.000	ST	
22	5.470-034.0	Kupplung	1.000	ST	
23	5.321-509.0	Griff	1.000	ST	
24	7.303-065.0	Bl.Schr. ST3,5X25-ST-A2R (IN6RD)	1.000	ST	
25	6.368-076.0	Zierkappe D10/D12	1.000	ST	
26	5.009-902.0	Halteblech Wasserfilter	1.000	ST	
27	4.071-210.0	Frischwassertank nur fuer Ersatz B 90 R	1.000	ST	
28	6.389-692.0	Schlauchnippel 1/2"	1.000	ST	
29	2.816-102.3	E-Ausruestung B 90 R	1.000	ST	
30	5.673-147.0	Stopfen	2.000	ST	
31	6.682-933.0	Drucksensor	1.000	ST	
32	6.390-074.0	Schlauch DN 4	1.000	M	ALS METERWARE BESTELLEN
33	6.391-821.0	Winkeltuelle R 1/4-4mm	1.000	ST	

## 11 Frischwassertank

POS	Artikelnr.	Beschreibung	Anzahl	Einheit	Fußnotentext
34	5.190-290.0	Deckel Sicherung	1.000	ST	
35	6.632-439.0	Schwimmerschalter Befuellsystem	1.000	ST	
36	6.465-031.0	Anschluss 3/4	1.000	ST	
37	5.007-949.0	Blech	5.000	ST	
38	5.515-327.0	Verlaengerung 3/4"	1.000	ST	
39	4.630-009.0	Summer ET Kit	1.000	ST	
40	6.363-600.0	O-Ring	1.000	ST	
41	6.414-985.0	Filtertasse	1.000	ST	
42	6.642-133.0	Netzstecker *EU	1.000	ST	
43	7.307-421.0	Gew.Stift M6x70-A2-21H ISO 4026	2.000	ST	
44	7.306-204.0	Schraube M 3X 10-A2-70 (IN6RD)	2.000	ST	
45	6.390-573.0	Schlauch D 16 X 4	1.000	M	ALS METERWARE BESTELLEN
46	6.273-055.0	Profildichtung	1.000	M	ALS METERWARE BESTELLEN
47	6.390-892.0	Spiralschlauch NW12	1.000	M	ALS METERWARE BESTELLEN
48	6.414-835.0	Filtereinsatz	1.000	ST	
49	7.306-184.0	Schraube M5x30 -A2-70 (In6Rd)	2.000	ST	
50	7.311-421.0	6kt-Mutter M 5-04-A2E ISO 10511	2.000	ST	
51	4.040-710.0	Halter	1.000	ST	
52	5.064-298.0	Verkleidung Lenksaeule	1.000	ST	
53	6.273-268.0	Dichtung Moosgummi	2.000	M	
54	7.644-007.0	Sicherungseinsatz C 7,5 DIN 72581-3	1.000	ST	
55	6.431-277.3	Bowdenzug Saugbalken	1.000	ST	



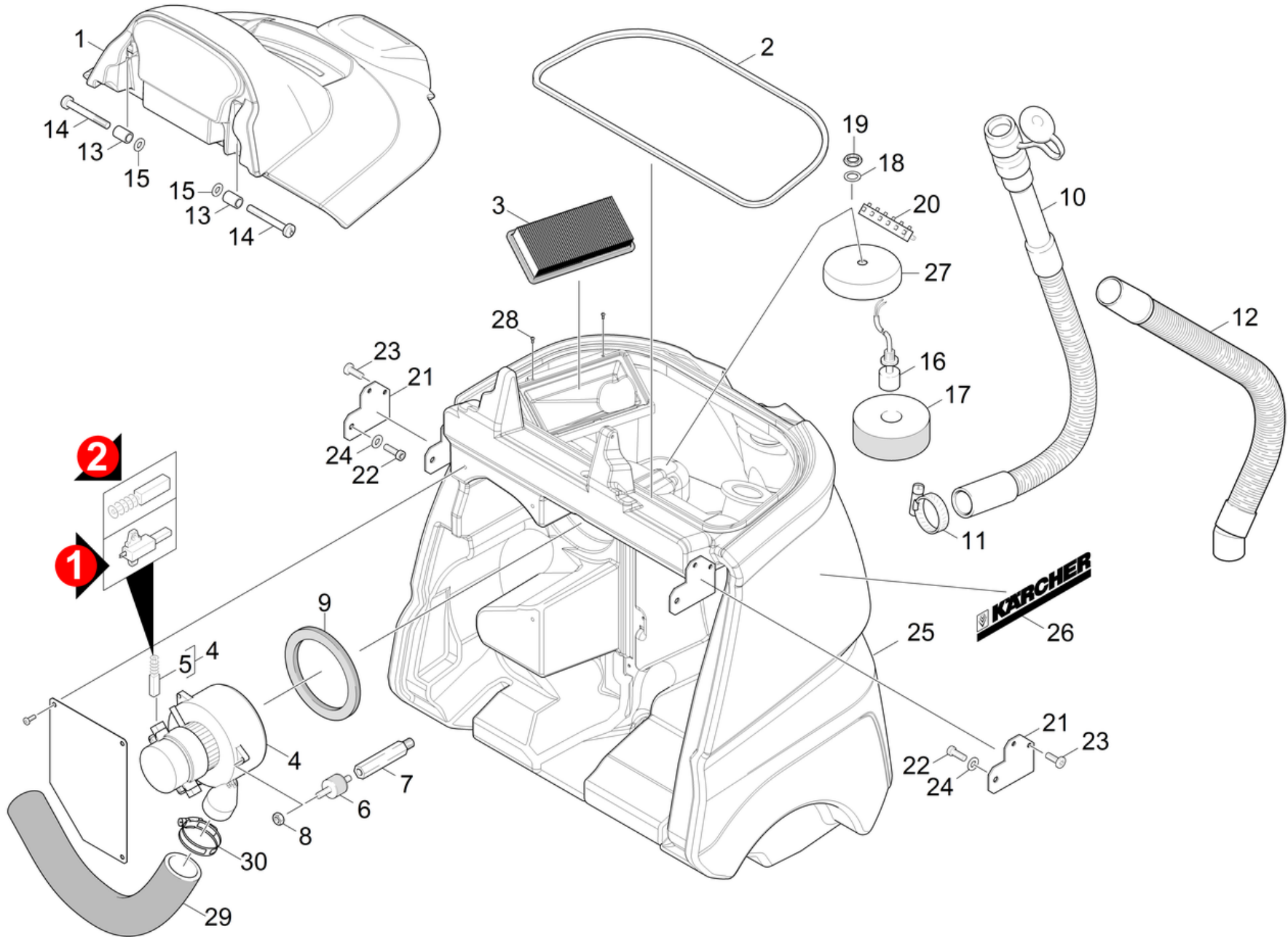

## 12 Schmutzwassertank

POS	Artikelnr.	Beschreibung	Anzahl	Einheit	Fußnotentext
1	5.064-257.0	Deckel Tank	1.000	ST	
2	6.366-043.0	Dichtungsprofil	1.000	M	ALS METERWARE BESTELLEN
3	6.414-976.0	Filter nur fuer Ersatz	1.000	ST	
4	6.490-000.0	Saugturbine 24V 420W	1.000	ST	VERSION 1
4	4.035-054.0	Saugturbine Ersatz	1.000	ST	VERSION 2
5	6.490-260.0	Kohlebuerstensatz	1.000	ST	VERSION 2
5	6.490-230.0	Kohlebuerstensatz	1.000	ST	VERSION 1
6	6.339-021.0	Gummipuffer 2xM6-D20 H15	3.000	ST	
7	5.308-066.0	Stehbolzen	3.000	ST	
8	7.311-541.0	6kt-Mutter M 6-8-A2E EN 1661	3.000	ST	
9	5.363-574.0	Dichtring	1.000	ST	
10	6.392-332.0	Ablassschlauch DN38 B 90 R	1.000	ST	STANDARD
10	6.392-049.0	Ablassschlauch oefest DN38 B90 R	1.000	ST	OELFEST
11	6.388-713.0	Schlauchschelle	1.000	ST	
12	6.391-698.0	Saugschlauch DN 38 - Big Trike	1.000	ST	
13	5.116-356.0	Huelse	2.000	ST	
14	7.303-114.0	Schraube 6 x 35-ST-10.9-R2R (IN6RD)	2.000	ST	
15	7.312-276.0	Scheibe 6 -200HV-A2E ISO7093-1	2.000	ST	
16	6.632-000.0	Schwimmerschalter	1.000	ST	
17	5.585-041.0	Schwimmer Schaumstop	1.000	ST	
18	6.641-654.0	Flachdichtung 13X20	1.000	ST	
19	6.641-483.0	Gegenmutter PG7	1.000	ST	
20	6.643-556.0	Anschlussklemme	1.000	ST	
21	5.009-538.0	Blech Verbindung	2.000	ST	
22	6.304-013.0	Zyl.Schr. M 8X 16	2.000	ST	
23	7.306-089.0	Schraube M6x12 -8.8-R2R (In6Rd)	4.000	ST	
24	7.313-004.0	Federring B 8-FSt-A3E DIN 127	2.000	ST	
25	4.071-211.0	Schmutzwassertank nur fuer Ersatz B 90 R	1.000	ST	
26	5.383-754.0	Schild	2.000	ST	
27	5.033-416.0	Haube Schwimmer	1.000	ST	
28	7.303-104.0	Schraube 5x16 -A2-70 (IN6RD)	2.000	ST	
29	6.390-215.0	Schalldaemmschlauch	1.000	ST	
30	6.388-563.0	Schlauchschelle	1.000	ST	

## 20 Fahrwerk

---

<b>POS</b>	<b>Beschreibung</b>	<b>Anzahl</b>	<b>Einheit</b>
21	Pedal	1.000	ST
22	Rammschutz	1.000	ST
23	Einzelteile	1.000	ST

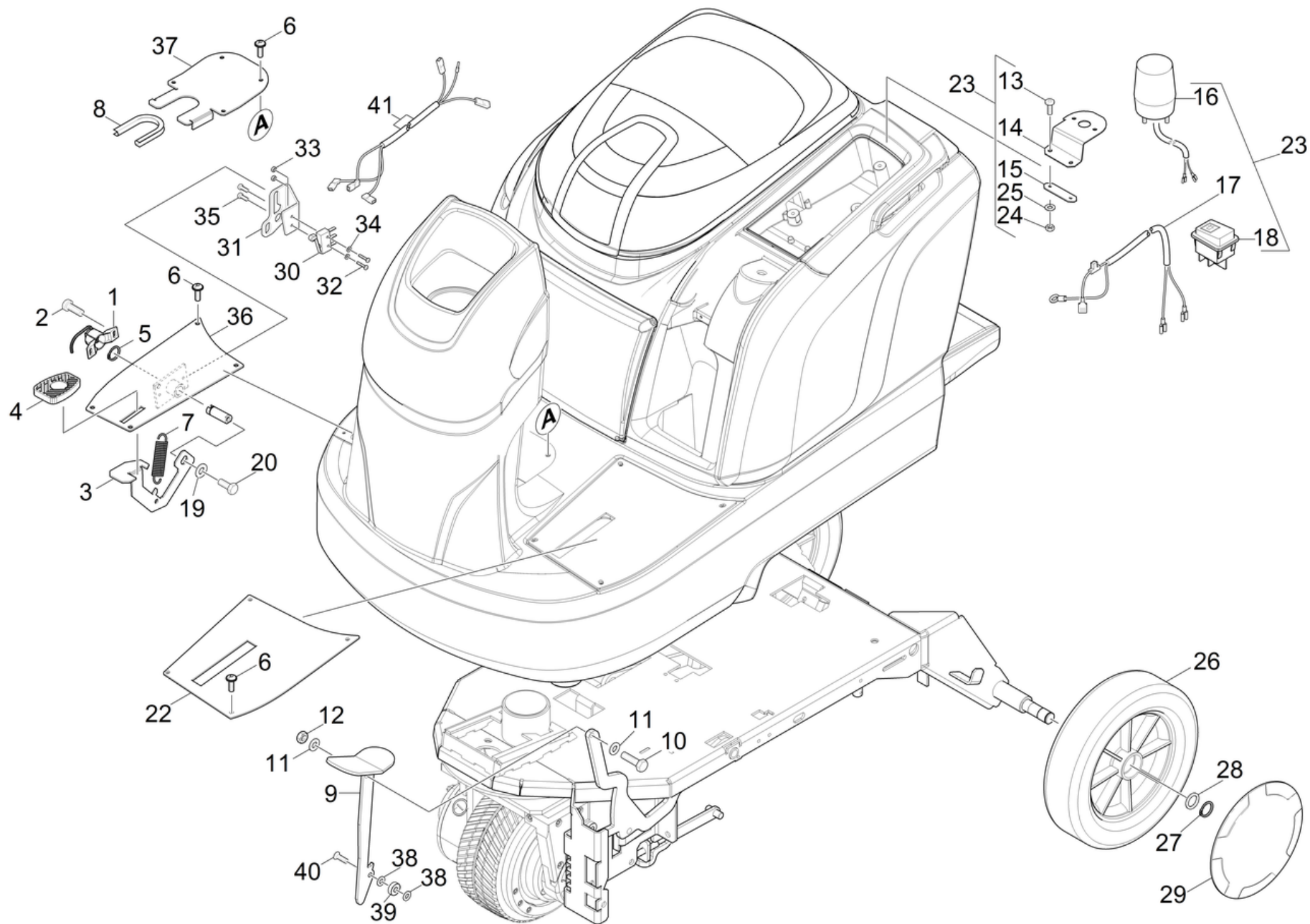

## 21 Pedal

POS	Artikelnr.	Beschreibung	Anzahl	Einheit	Fußnotentext
1	4.683-089.0	Steuerung Fahrregler Sensor B90R	1.000	ST	
2	7.303-037.0	Schraube M5x10 -St-P2R (In6Rd)	2.000	ST	
3	5.062-426.0	Blech Gaspedal	1.000	ST	
4	6.321-046.0	Ueberzug Pedal	1.000	ST	
5	7.343-005.0	Sicherungsring 16x1-FST-PHR DIN 471	1.000	ST	
6	7.303-107.0	Schraube 5x16 -10.9-P2R (K-In6Rd)	12.000	ST	
7	6.330-241.0	Zugfeder	1.000	ST	
8	6.368-018.0	Kantenschutz	1.000	M	ALS METERWARE BESTELLEN
9	4.481-273.0	Pedal Anhebung Bodenkopf	1.000	ST	
10	7.304-399.0	6kt-Schraube M 8x25-8.8-A2E ISO 4017	1.000	ST	
11	7.312-004.0	Scheibe 8 -200HV-A3E ISO 7090	2.000	ST	
12	7.311-510.0	6kt-Mutter M 8-8-A2E ISO 7040	1.000	ST	
13	7.306-077.0	Schraube M5x16 -8.8-R2R (In6Rd)	2.000	ST	
14	5.010-058.0	Halblech Warnlampe	1.000	ST	
15	5.010-059.0	Blech	1.000	ST	
16	6.651-635.0	Blitzleuchte orange 24 V	1.000	ST	
17	4.822-562.0	Kabelbaum Blitzer	1.000	ST	
18	6.632-369.0	Schalter 2-polig Rundumkennleuchte	1.000	ST	
19	7.312-289.0	Scheibe 8 -A2 ISO 7093-1	1.000	ST	
20	7.304-538.0	6kt-Schraube M8x16-A4-70 ISO 4017	1.000	ST	
21	4.033-756.0	Bodenblech kpl.	1.000	ST	
22	5.009-524.0	Bodenblech links	1.000	ST	
23	2.641-718.0	Anbausatz	1.000	ST	
24	7.311-002.0	6kt-Mutter M5 -8-A2E ISO 4032	2.000	ST	
25	7.312-002.0	Scheibe 5-200HV-A3E ISO 7090	2.000	ST	
26	6.435-350.0	Rad	2.000	ST	
27	7.343-040.0	Sicherungsring 20x1,2 -St-ph DIN 471	2.000	ST	
28	5.115-733.0	Scheibe	2.000	ST	
29	5.064-391.0	Radkappe	2.000	ST	
30	6.630-732.0	Schalter vergoldet	1.000	ST	
31	5.065-742.0	Halblech Mikroschalter	1.000	ST	
32	7.306-045.0	Schraube M2x20 -4.8-A2K DIN 84	2.000	ST	
33	7.311-074.0	6kt-Mutter M 2-8-A2E ISO 4032	2.000	ST	

## 21 Pedal

---

<b>POS</b>	<b>Artikelnr.</b>	<b>Beschreibung</b>	<b>Anzahl</b>	<b>Einheit</b>	<b>Fußnotentext</b>
34	7.312-053.0	Scheibe 2,5-200HV-A3E ISO 7089	2.000	ST	
35	7.306-213.0	Schraube M5x6 -A2-70 (In6Rd)	2.000	ST	
36	4.033-756.0	Bodenblech kpl.	1.000	ST	
37	5.009-531.0	Abdeckblech Lenkung	1.000	ST	
38	7.312-004.0	Scheibe 8 -200HV-A3E ISO 7090	2.000	ST	
39	7.401-149.0	Kugellager 608-2RS -Wälzl.St DIN 625	1.000	ST	
40	7.305-013.0	Senkschraube M8x20-8.8-A2R ISO10642	1.000	ST	
41	2.641-417.0	UBS Kabelkit Mikroschalter B 90	1.000	ST	

## 23 Anbausatz (2.641-718.0)

---

<b>POS</b>	<b>Artikelnr.</b>	<b>Beschreibung</b>	<b>Anzahl</b>	<b>Einheit</b>
10	5.010-058.0	Halblech Warnlampe	1.000	ST
20	5.010-059.0	Blech	1.000	ST
30	6.651-635.0	Blitzleuchte orange 24 V	1.000	ST
40	4.822-562.0	Kabelbaum Blitzer	1.000	ST
50	6.632-476.0	Schalter 2-polig Leuchte	1.000	ST
70	6.641-459.0	Kabelschelle	3.000	ST
80	7.311-002.0	6kt-Mutter M5 -8-A2E ISO 4032	1.000	ST
90	7.312-002.0	Scheibe 5-200HV-A3E ISO 7090	1.000	ST
100	7.306-077.0	Schraube M5x16 -8.8-R2R (In6Rd)	2.000	ST

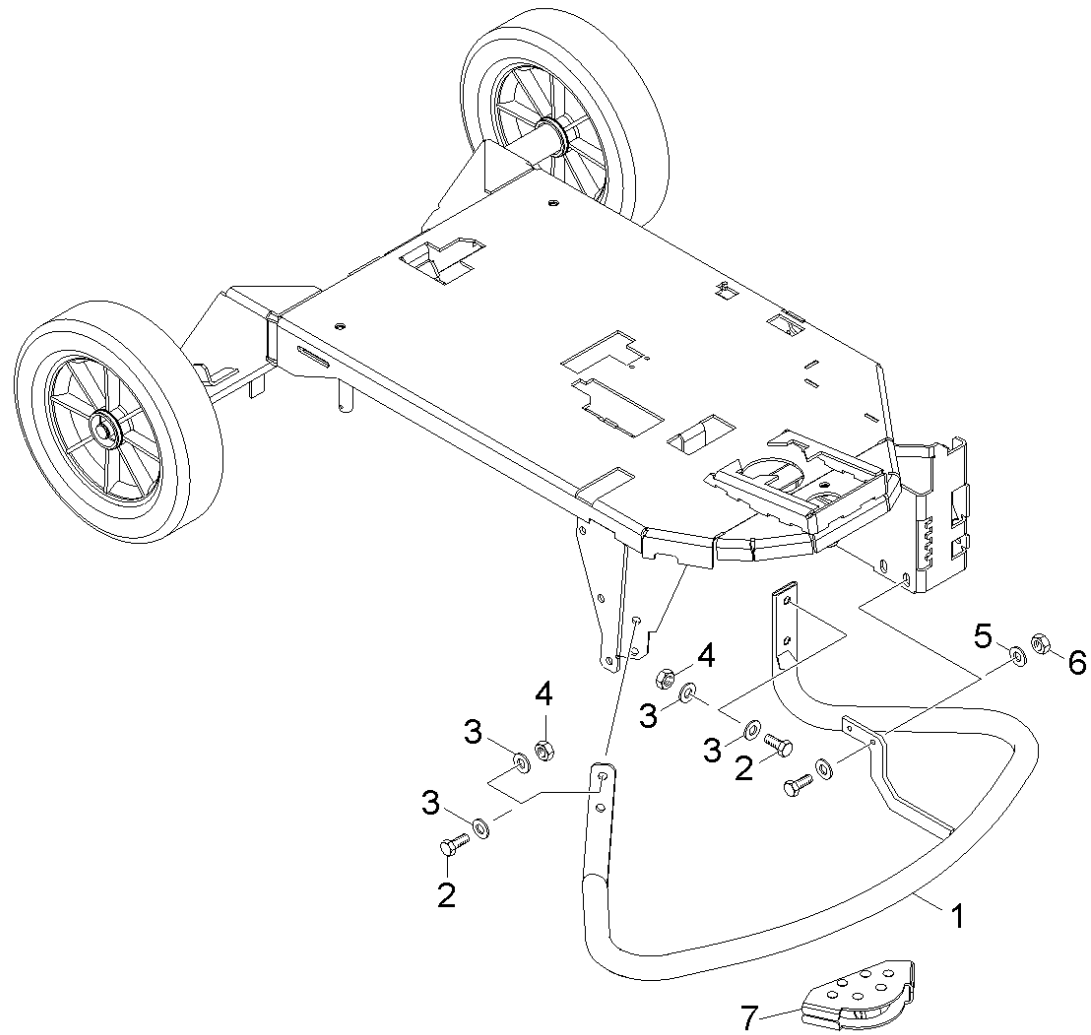



## 22 Rammschutz

---

<b>POS</b>	<b>Artikelnr.</b>	<b>Beschreibung</b>	<b>Anzahl</b>	<b>Einheit</b>
1	4.040-727.0	Rammschutz	1.000	ST
2	7.304-415.0	6kt-Schraube M10x25-8.8-A3E ISO 4017	4.000	ST
3	7.312-005.0	Scheibe 10-200HV-A3E ISO 7090	8.000	ST
4	7.311-511.0	6kt-Mutter M10-8-A2E ISO 7040	4.000	ST
5	7.312-004.0	Scheibe 8 -200HV-A3E ISO 7090	1.000	ST
6	7.311-510.0	6kt-Mutter M 8-8-A2E ISO 7040	1.000	ST
7	2.641-773.0	ABS Lenkrolle	1.000	ST

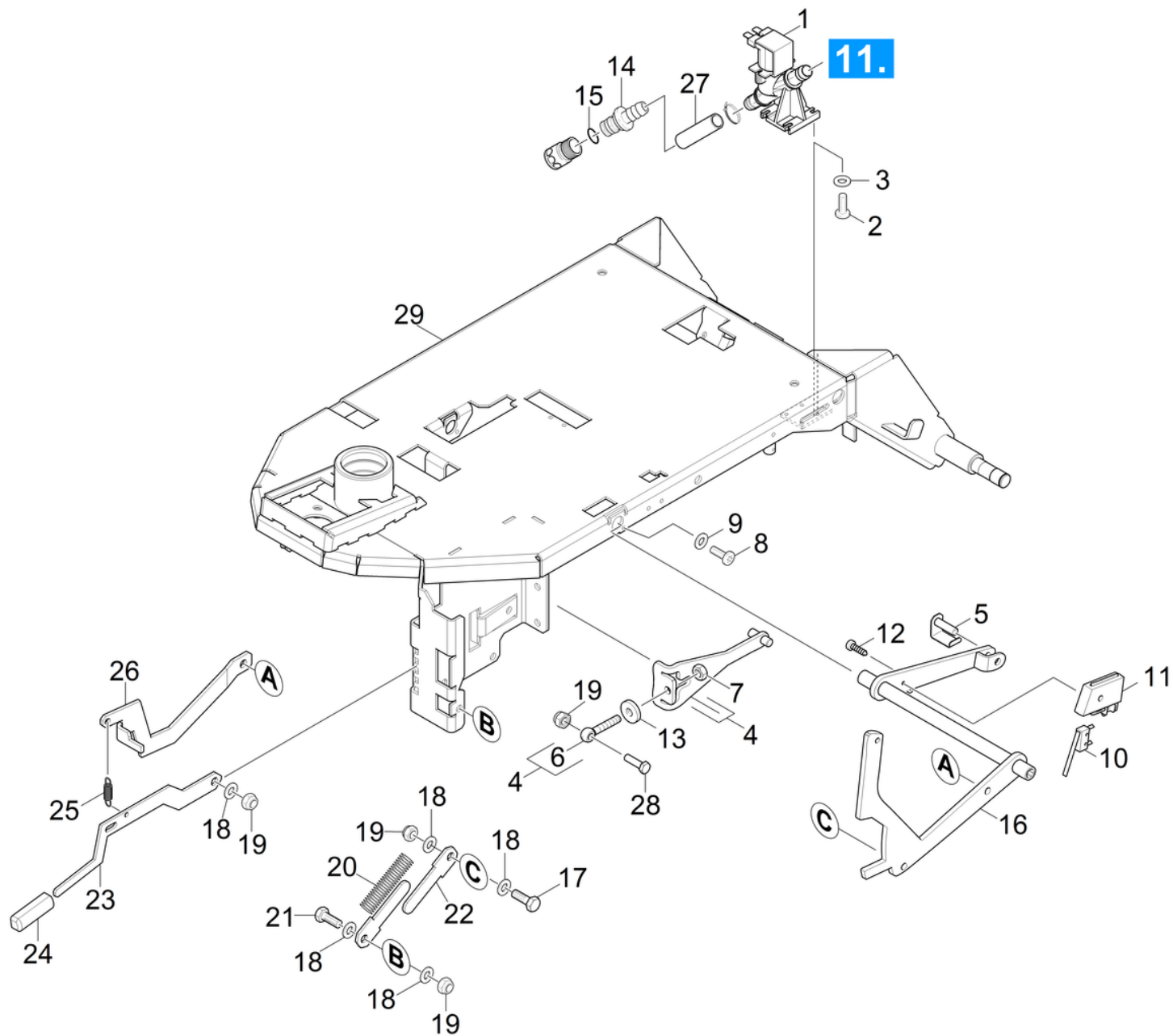

## 23 Einzelteile

POS	Artikelnr.	Beschreibung	Anzahl	Einheit	Bemerkung	Fußnotentext
1	4.035-196.0	Magnetventil fuer Ersatz 24 V	1.000	ST		
2	7.306-058.0	Schraube M 4X 12- 8.8-R2R K-IN6RD	4.000	ST		
3	7.311-569.0	4kt-Mutter M4 -04-A2E DIN 562	4.000	ST		
4	4.481-299.0	Kit Zugstange	2.000	ST		
5	4.481-243.0	Verriegelung	1.000	ST		
6	6.401-475.0	Augenschraube LB-5.6 M10x70	2.000	ST	M10x70	AUSFUEHRUNG BEACHTEN
6	6.401-419.0	Augenschraube LB M10x60 DIN 444	2.000	ST	M10x60	AUSFUEHRUNG BEACHTEN
7	7.311-006.0	6kt-Mutter M10 -8-A3E ISO 4032	2.000	ST		
8	7.303-047.0	Schraube M6x16 -St-R3R (In6Rd)	2.000	ST		
9	7.312-003.0	Scheibe 6 -200HV-A3E ISO 7090	2.000	ST		
10	6.630-398.0	Mikroschalter	1.000	ST		
11	5.060-998.0	Gehaeuse Mikroschalter	1.000	ST		
12	7.303-065.0	Bl.Schr. ST3,5X25-ST-A2R (IN6RD)	1.000	ST		
13	7.310-041.0	Raendelmutter M10- St-E2E DIN 467	2.000	ST		
14	5.443-375.0	Schlauchnippel	1.000	ST		
15	6.362-170.0	O-Ring 11,3 X 2,4-NBR 70	1.000	ST		
16	4.481-240.0	Hebel Buerstenkopf	1.000	ST		
17	7.304-417.0	6kt-Schraube M10x30-8.8-A3E ISO 4017	1.000	ST		
18	7.312-005.0	Scheibe 10-200HV-A3E ISO 7090	10.000	ST		
19	7.311-511.0	6kt-Mutter M10-8-A2E ISO 7040	3.000	ST		
20	5.332-962.0	Druckfeder	1.000	ST		
21	7.304-415.0	6kt-Schraube M10x25-8.8-A3E ISO 4017	1.000	ST		
22	5.009-763.0	Blech Halter Feder	1.000	ST		
23	5.062-283.0	Blech Anpressdruck	1.000	ST		
24	5.321-457.0	Griff	1.000	ST		
25	6.330-409.0	Zugfeder	1.000	ST		
26	5.009-490.0	Blech Anpressdruck	1.000	ST		
27	6.388-248.0	Schlauch DN12,5	1.000	M		ALS METERWARE BESTELLEN
28	7.304-419.0	6kt-Schraube M10x35-8.8-A3E ISO 4017	2.000	ST		
29	4.050-881.0	Rahmen BR/BD 65/90 R	1.000	ST		

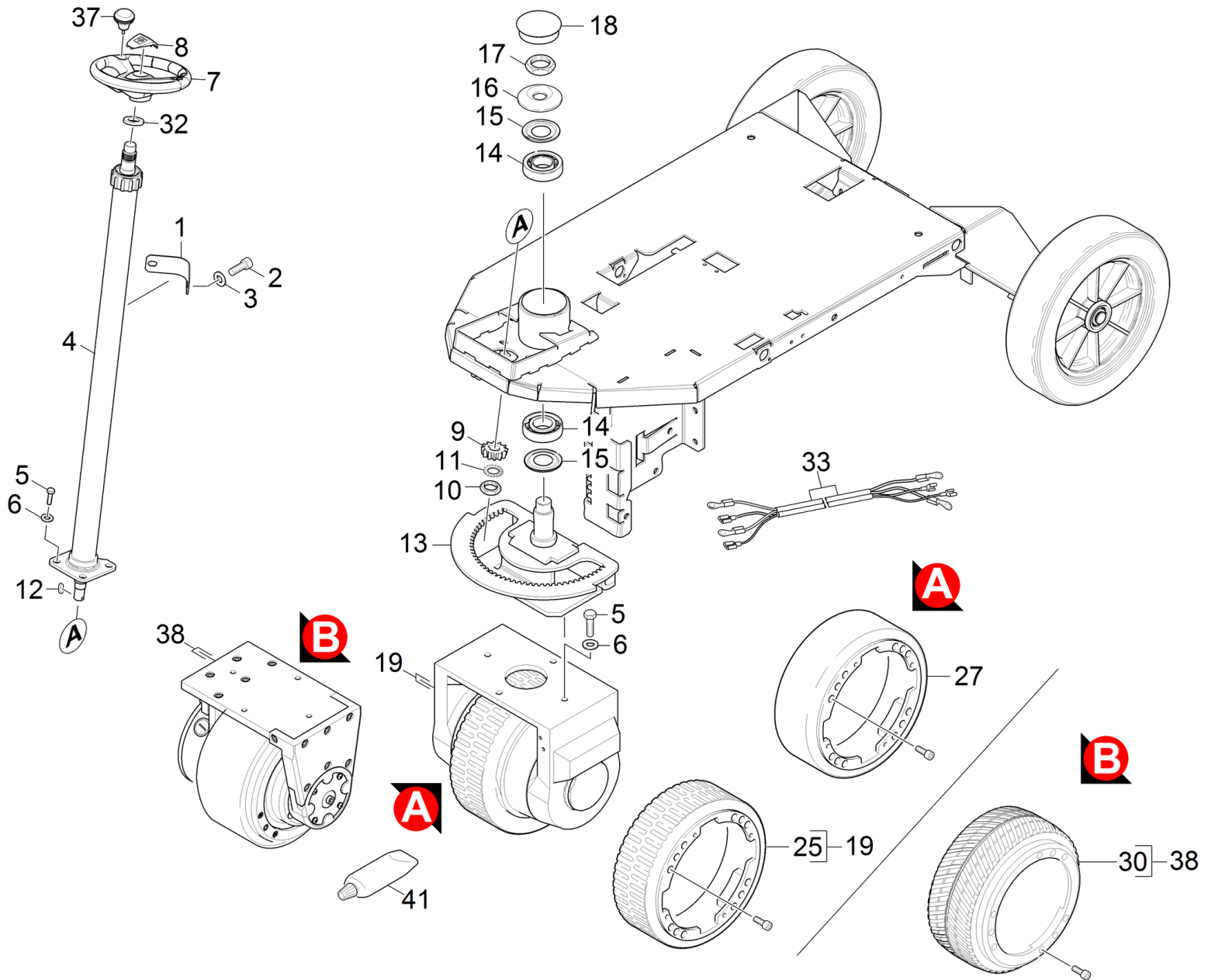

## 30 Lenkung

POS	Artikelnr.	Beschreibung	Anzahl	Einheit	Bemerkung	Fußnotentext
1	5.009-542.0	Blech Lenksaeule	1.000	ST		
2	7.306-040.0	Zyl.Schr. M8x16 -8.8-A2E ISO4762	2.000	ST		
3	7.312-004.0	Scheibe 8 -200HV-A3E ISO 7090	2.000	ST		
4	6.439-202.0	Lenksaeule BR 65/90	1.000	ST		
5	7.304-415.0	6kt-Schraube M10x25-8.8-A3E ISO 4017	8.000	ST		
6	7.313-005.0	Federring B10-FSt-A3E DIN 127	8.000	ST		
7	6.435-795.0	Lenkrad	1.000	ST		
8	6.640-353.0	Abdeckkappe Lenkrad KÄRCHER	1.000	ST		
9	5.352-090.0	Zahnrad	1.000	ST		
10	7.311-059.0	6kt-Mutter M16x1,5 -8-A2E ISO10512	1.000	ST		
11	7.312-035.0	Faecherscheibe A17-1.4310 DIN 6798	1.000	ST		
12	7.318-084.0	Passfeder 5x5x12 -C45R DIN 6885-1	1.000	ST		
13	4.250-001.0	Flanschlager kpl.	1.000	ST		
14	6.401-260.0	Schraegkugellager	2.000	ST		
15	6.401-263.0	Schleifring	2.000	ST		
16	7.312-010.0	Scheibe 24 -200HV-A3E ISO 7090	1.000	ST		
17	7.311-122.0	6kt-Mutter M24X1,5-22H-A2E DIN 936	1.000	ST		
18	6.368-215.0	Abdeckkappe	1.000	ST		
19	6.613-315.0	Fahrmotor	1.000	ST		VERSION A
25	6.435-402.0	Reifen Trike	1.000	ST		VERSION A
27	6.435-417.0	Reifen Trike	1.000	ST	VERSION A	OELFEST
30	6.435-854.0	Rad Fahrmotor	1.000	ST		VERSION B
32	7.312-065.0	Scheibe 22-A2 ISO 7090	1.000	ST		
33	6.650-076.0	Kabelsatz nur für Ersatz	1.000	ST		
37	6.640-354.0	Drehgriff	1.000	ST		
38	6.613-206.3	Fahrmotor 600W	1.000	ST		VERSION B
41	6.288-134.0	Schmierfett gleitmo WSP 5040	1.000	ZST		

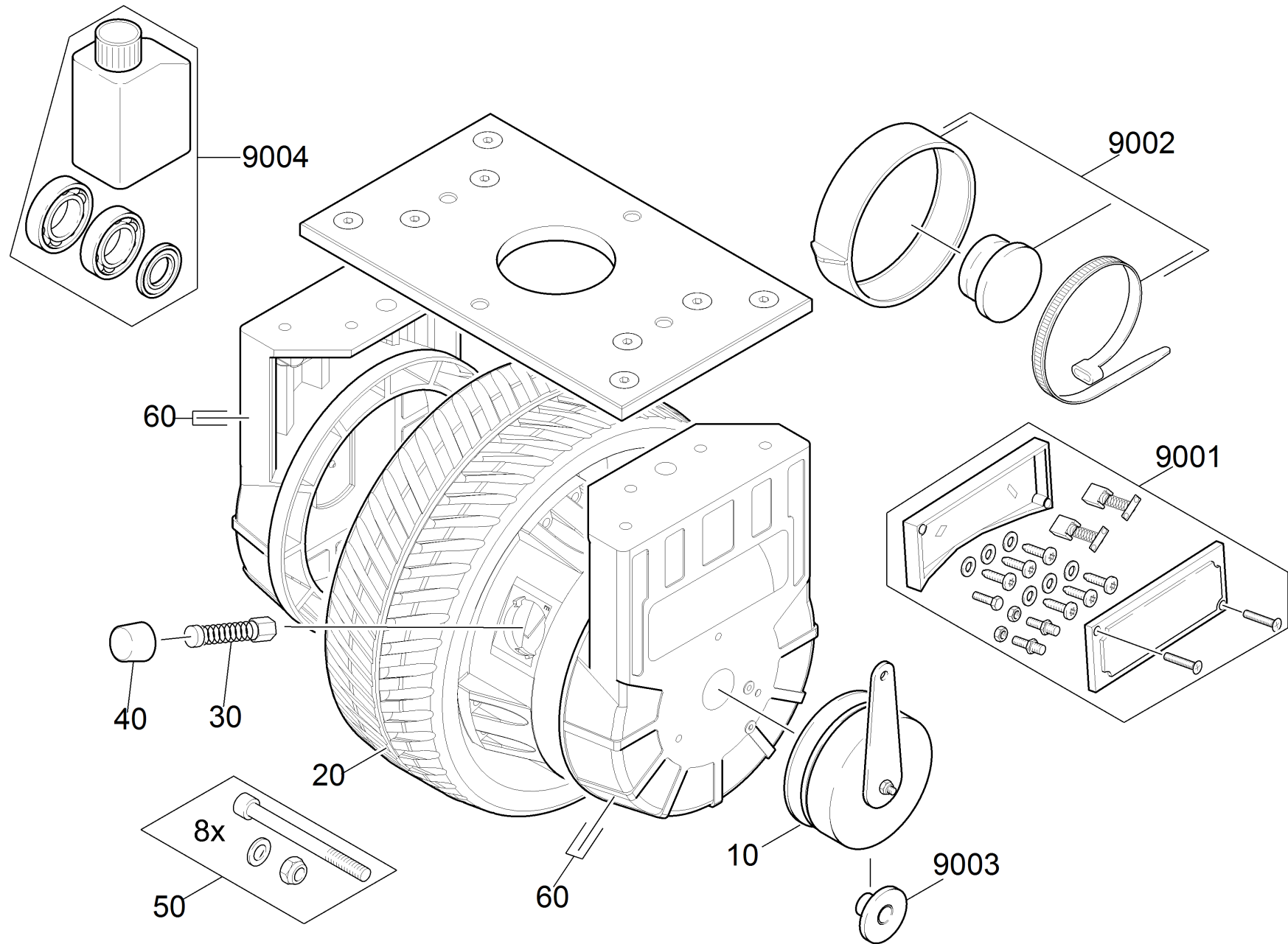

## 19 Fahrmotor (6.613-315.0)

---

<b>POS</b>	<b>Artikelnr.</b>	<b>Beschreibung</b>	<b>Anzahl</b>	<b>Einheit</b>	<b>Fußnotentext</b>
10	4.467-002.0	Bremse einstellbar kpl.	1.000	ST	VERSION A
20	6.435-402.0	Reifen Trike	1.000	ST	
30	6.610-211.0	Kohlebuerstensatz	1.000	ST	VERSION A
40	6.961-901.0	Kappe mit Bajonett	4.000	ST	VERSION A
50	6.610-329.0	Ersatzteil-Set Schraube Felge	1.000	ST	VERSION A
60	6.613-476.0	Flansch Getriebe Ersatz	1.000	ST	
9001	6.610-328.0	Ersatzteil-Set Klemmenkasten Fahrmotor	1.000	ST	VERSION A
9002	6.467-039.0	Nachruestsatz Bremse	1.000	ST	
9003	6.394-391.0	Kupplung Bremse BR/BD TRIKE	1.000	ST	VERSION A
9004	4.641-045.0	Ersatzteil Set Lager	1.000	ST	VERSION A

## 9004 Ersatzteil Set Lager (4.641-045.0)

---

<b>POS</b>	<b>Artikelnr.</b>	<b>Beschreibung</b>	<b>Anzahl</b>	<b>Einheit</b>
1	7.401-134.0	Kugellager 6203-2RS-WAELZLAGST DIN 625	1.000	ST
2	7.401-133.0	Kugellager 6004-2RS -Wälzl.St DIN 625	1.000	ST
4	6.997-364.0	Syntheseoel CLP 150 / 500 ml	1.000	ST



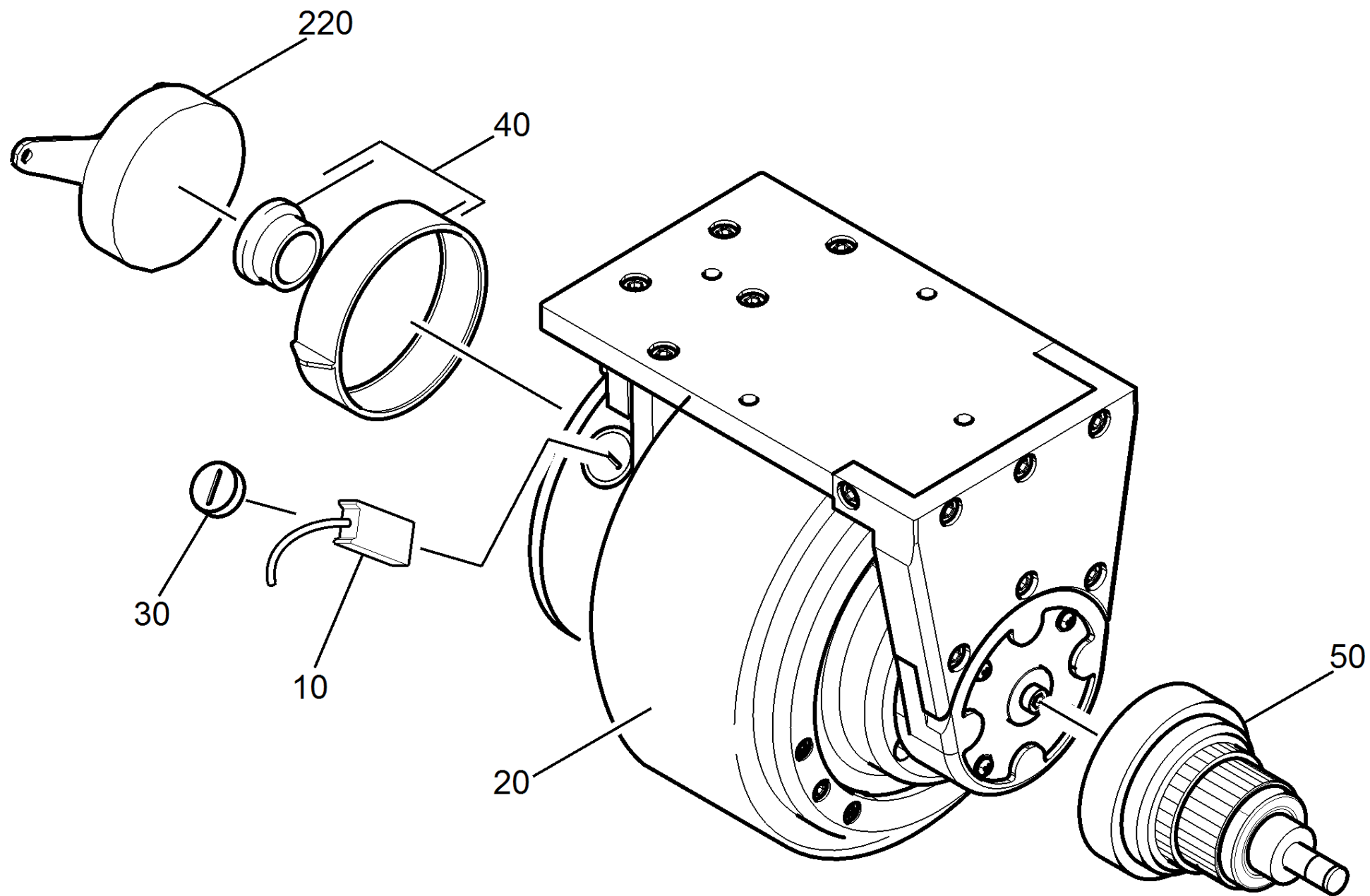

### 38 Fahrmotor 600W (6.613-206.3)

---

<b>POS</b>	<b>Artikelnr.</b>	<b>Beschreibung</b>	<b>Anzahl</b>	<b>Einheit</b>
10	6.613-231.0	Kohlebuerstensatz	1.000	ST
20	6.435-854.0	Rad Fahrmotor	1.000	ST
30	6.961-924.0	Deckel Verschluss	1.000	ST
40	6.467-039.0	Nachruestsatz Bremse	1.000	ST
50	6.550-042.0	Set Ankerwelle Fahrmotor	1.000	ST
220	4.467-000.0	Bremse einstellbar kpl.	1.000	ST
9000	6.288-134.0	Schmierfett gleitmo WSP 5040	1.000	ZST

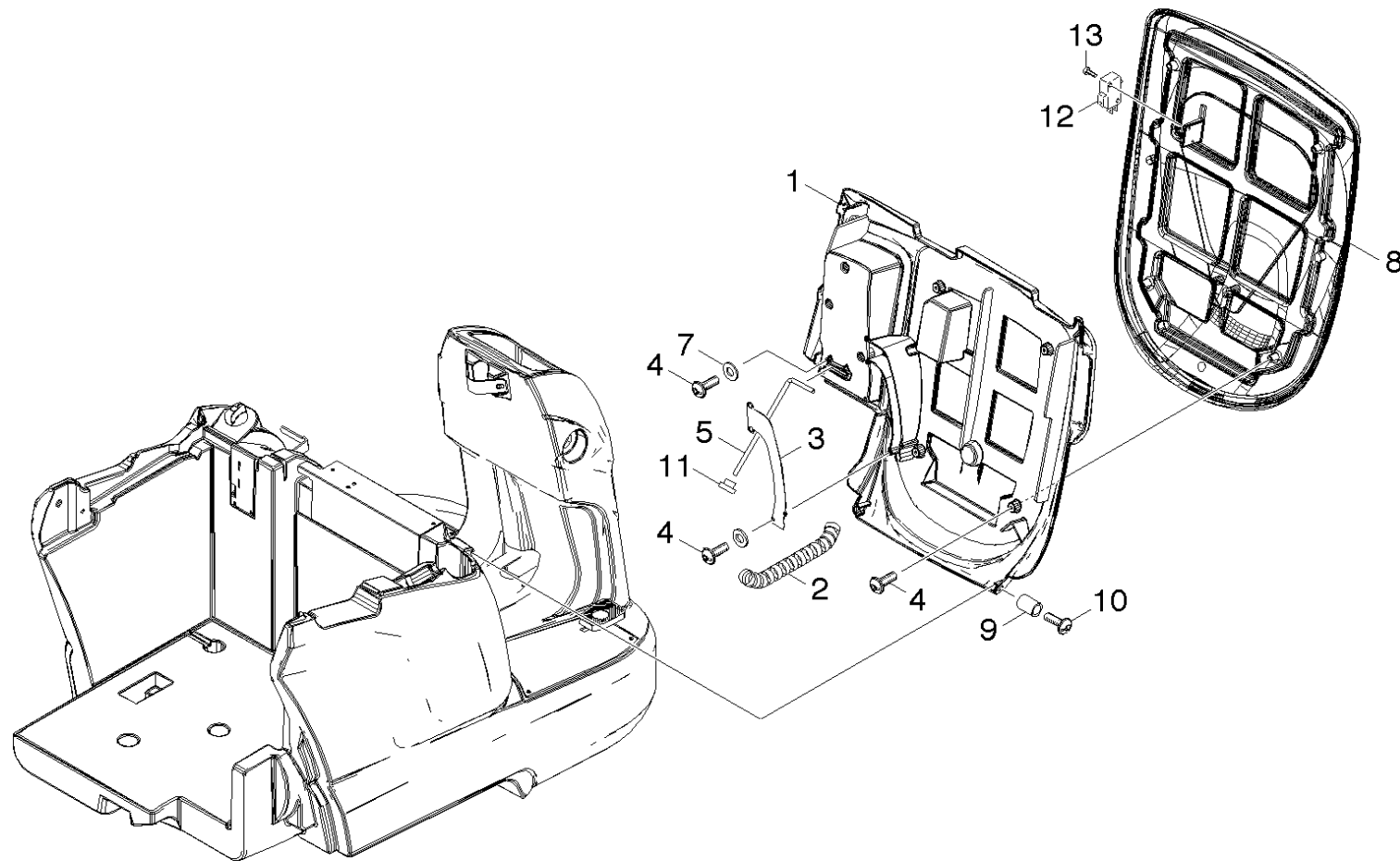

## 40 Sitz

POS	Artikelnr.	Beschreibung	Anzahl	Einheit	Fußnotentext
1	5.064-258.0	Deckel Sitz	1.000	ST	
2	6.390-219.0	Schutzschlauch	1.000	M	ALS METERWARE BESTELLEN
3	5.009-508.0	Abdeckblech	1.000	ST	
4	7.303-107.0	Schraube 5x16 -10.9-P2R (K-In6Rd)	10.000	ST	
5	5.107-278.0	Stange Deckel Sitz	1.000	ST	
6	7.303-107.0	Schraube 5x16 -10.9-P2R (K-In6Rd)	6.000	ST	
7	7.312-278.0	Scheibe 5-200HV-A2E ISO7093-1	2.000	ST	
8	6.394-973.0	Sitz	1.000	ST	
9	5.116-356.0	Huelse	2.000	ST	
10	7.303-114.0	Schraube 6 x 35-ST-10.9-R2R (IN6RD)	2.000	ST	
11	6.641-446.0	Kabeltuelle	1.000	ZST	
12	6.631-854.0	Mikroschalter	1.000	ST	
13	7.306-045.0	Schraube M2x20 -4.8-A2K DIN 84	2.000	ST	

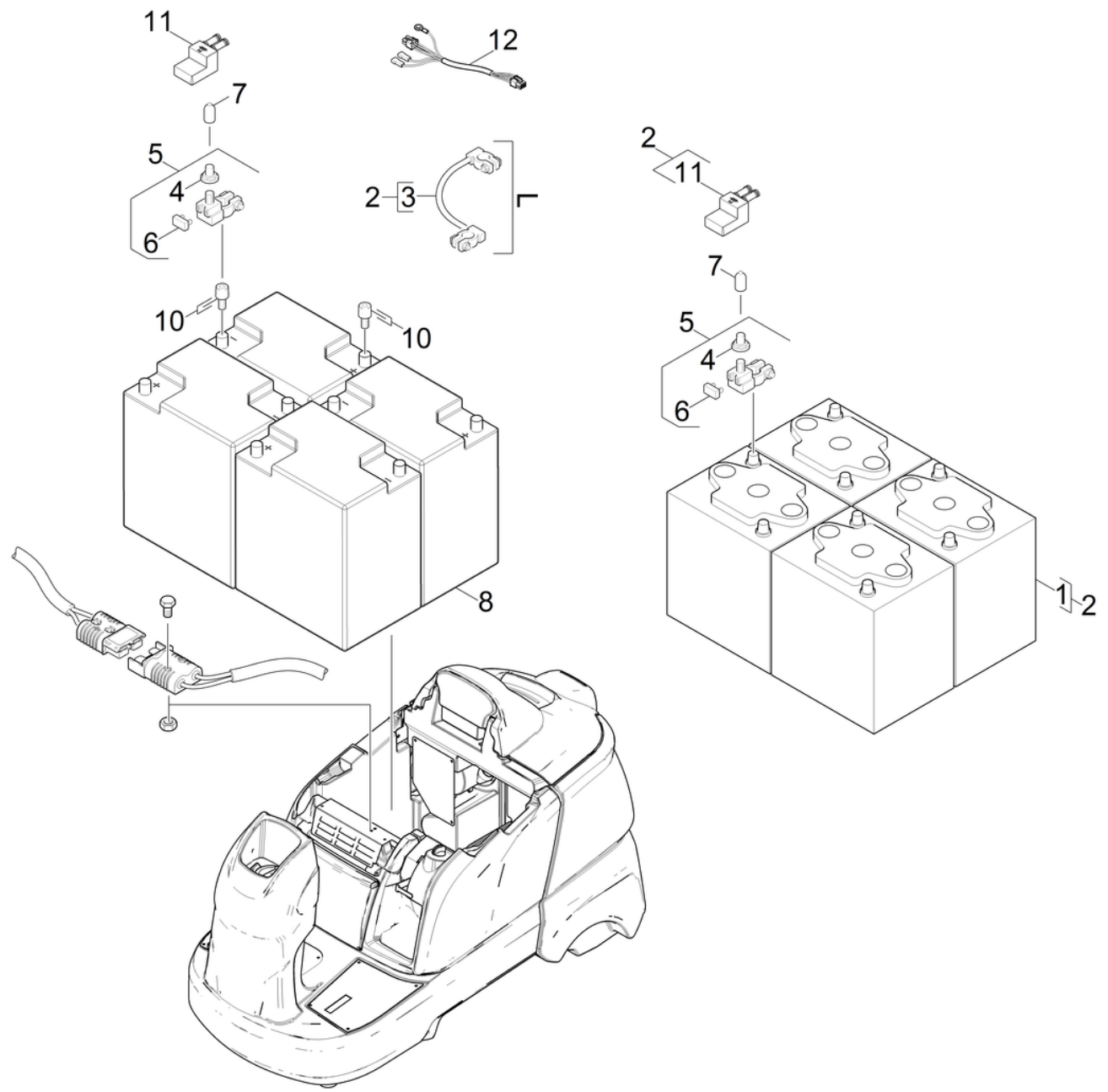

## 50 Batterie

POS	Artikelnr.	Beschreibung	Anzahl	Einheit	Bemerkung	Fußnotentext
1	6.654-124.0	Batterie DETA	4.000	ST	180Ah / "Exide"	
2	6.654-130.0	Batteriesatz DETA	1.000	ZSA	180Ah / "Exide"	
3	6.649-880.0	Kabel Batterie 25 mm <sup>2</sup>	3.000	ST	L=320mm	
3	6.649-879.0	Kabel Batterie 25 mm <sup>2</sup>	2.000	ST	L=160mm	
4	6.644-348.0	Mutter mit Flansch	1.000	ST		
5	6.643-948.0	Polklemme 1-fach	1.000	ST		
6	6.644-360.0	Sicherung 125A	1.000	ST		
7	6.368-187.0	Schutzstopfen	1.000	ST		
8	6.654-242.0	Antriebsbatterie wartungsfrei 170Ah	4.000	ST	170Ah / "Hoppecke"	WARTUNGSFREI
10	4.410-000.0	Batteriepole Set nur fuer Ersatz HOPPECK	1.000	ST		NUR FUER BATTERIE "HOPPECKE"
11	5.394-852.0	Abdeckung Batteriepol	1.000	ST		
12	4.822-538.0	Kabelbaum Pack	1.000	ST		

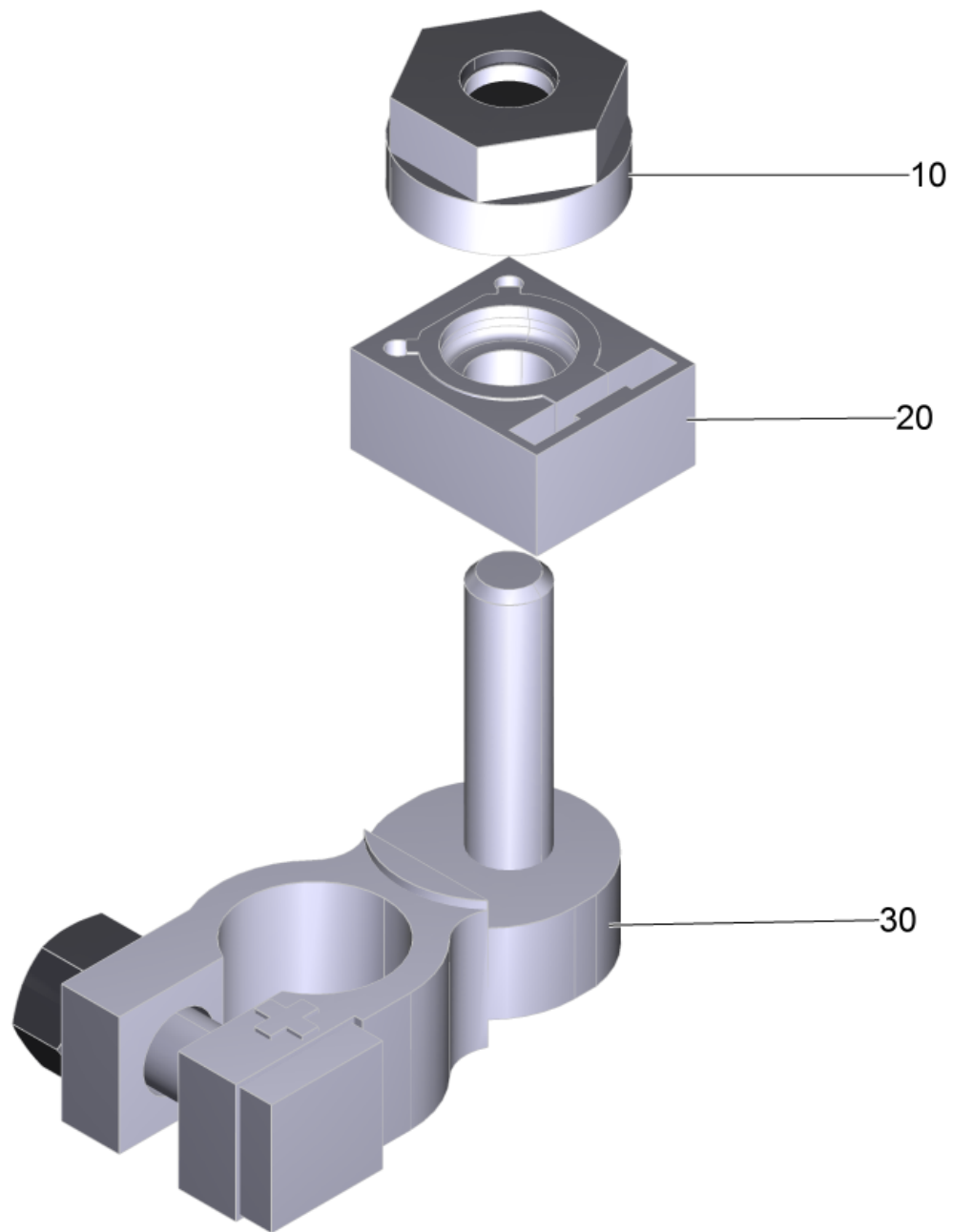

## 5 Polklemme 1-fach (6.643-948.0)

---

<b>POS</b>	<b>Artikelnr.</b>	<b>Beschreibung</b>	<b>Anzahl</b>	<b>Einheit</b>
10	6.644-348.0	Mutter mit Flansch	1.000	ST
20	6.644-360.0	Sicherung 125A	1.000	ST
30	6.644-530.0	Batterieklemme	1.000	ST



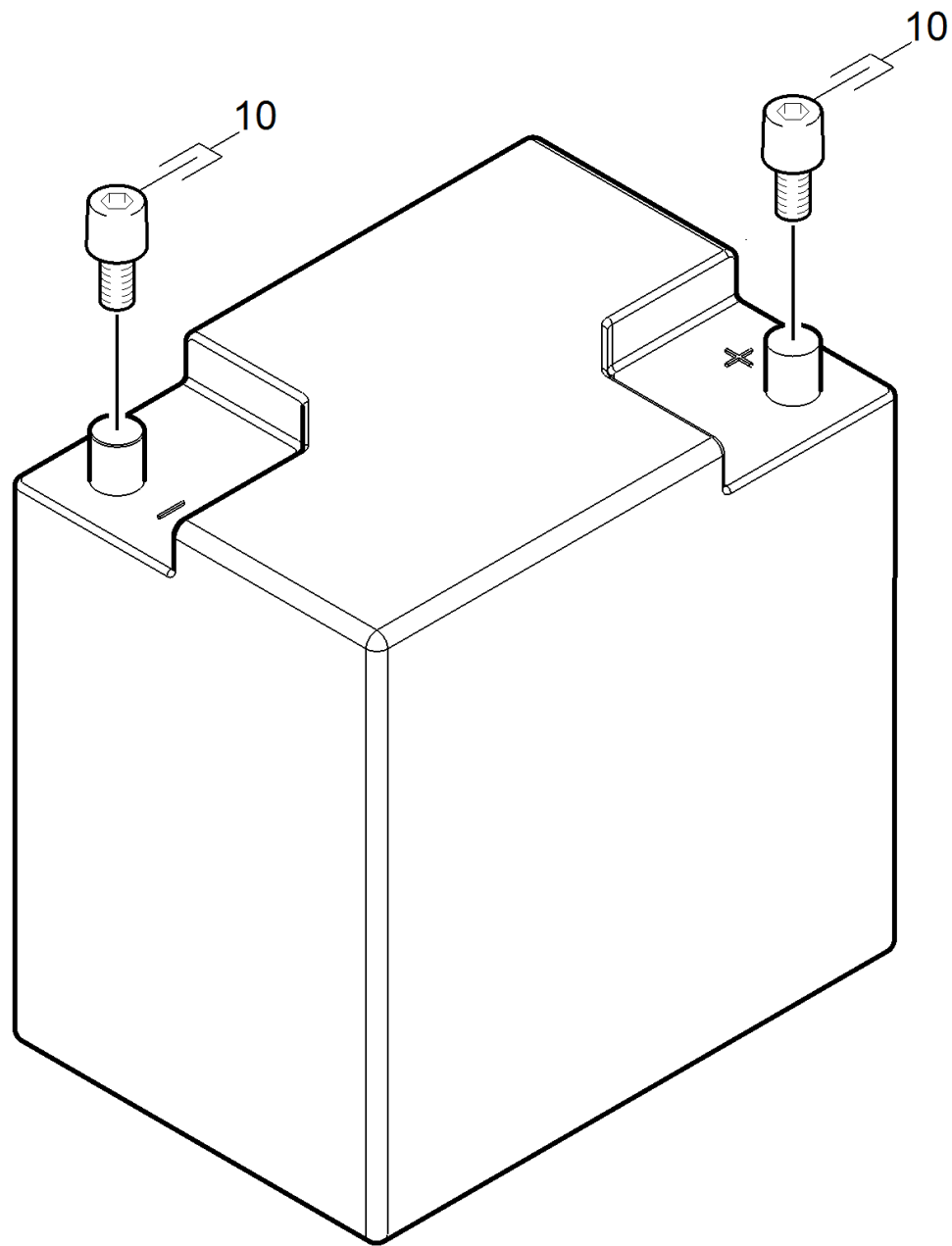

8 Antriebsbatterie wartungsfrei 170Ah (6.654-242.0)

---

<b>POS</b>	<b>Artikelnr.</b>	<b>Beschreibung</b>	<b>Anzahl</b>	<b>Einheit</b>
10	4.410-000.0	Batteriepole Set nur fuer Ersatz HOPPECK	1.000	ST

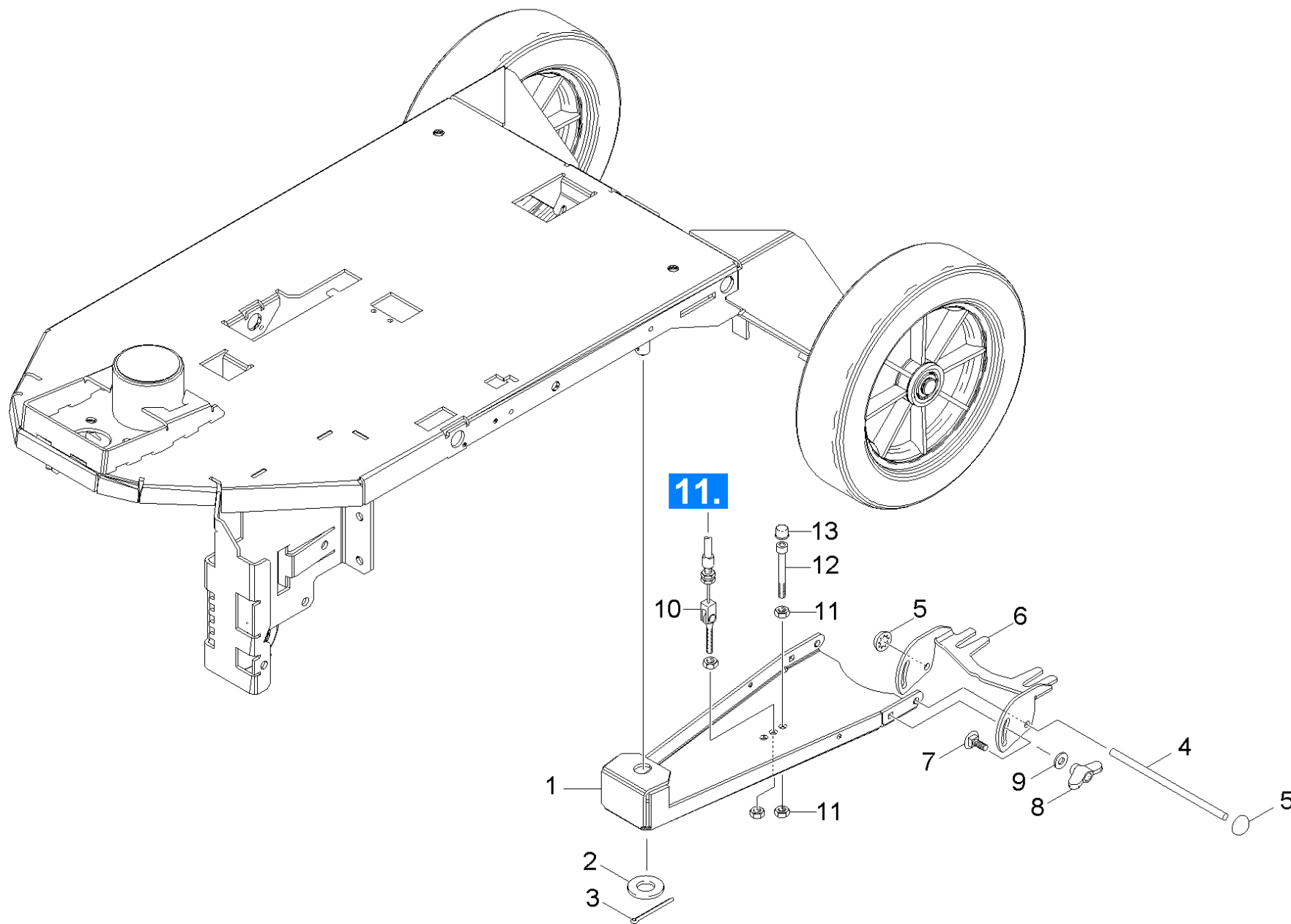

## 60 Saugbalkenanhebung

---

<b>POS</b>	<b>Artikelnr.</b>	<b>Beschreibung</b>	<b>Anzahl</b>	<b>Einheit</b>
1	5.009-502.0	Blech Saugbalken	1.000	ST
2	7.312-019.0	Scheibe 16-200HV-A3E ISO7090	1.000	ST
3	7.316-352.0	Splint 4x36 -St-A2E ISO 1234	1.000	ST
4	5.107-202.0	Stange	1.000	ST
5	6.343-132.0	Sicherungsscheibe 8	2.000	ST
6	5.058-987.0	Wippe Saugbalken	1.000	ST
7	7.303-139.0	Fl.Rd.Schr. M6x20 -A2 DIN 603	2.000	ST
8	6.310-180.0	Fluegelmutter M6	2.000	ST
9	7.312-292.0	Scheibe 6 -A2 ISO 7093-1	2.000	ST
10	6.431-277.3	Bowdenzug Saugbalken	1.000	ST
11	7.311-004.0	6kt-Mutter M8 -8-A3E ISO 4032	2.000	ST
12	7.306-242.0	Zyl.Schr. M8x75-8.8-A2E ISO 4762	1.000	ST
13	6.368-295.0	Schutzkappe	1.000	ST

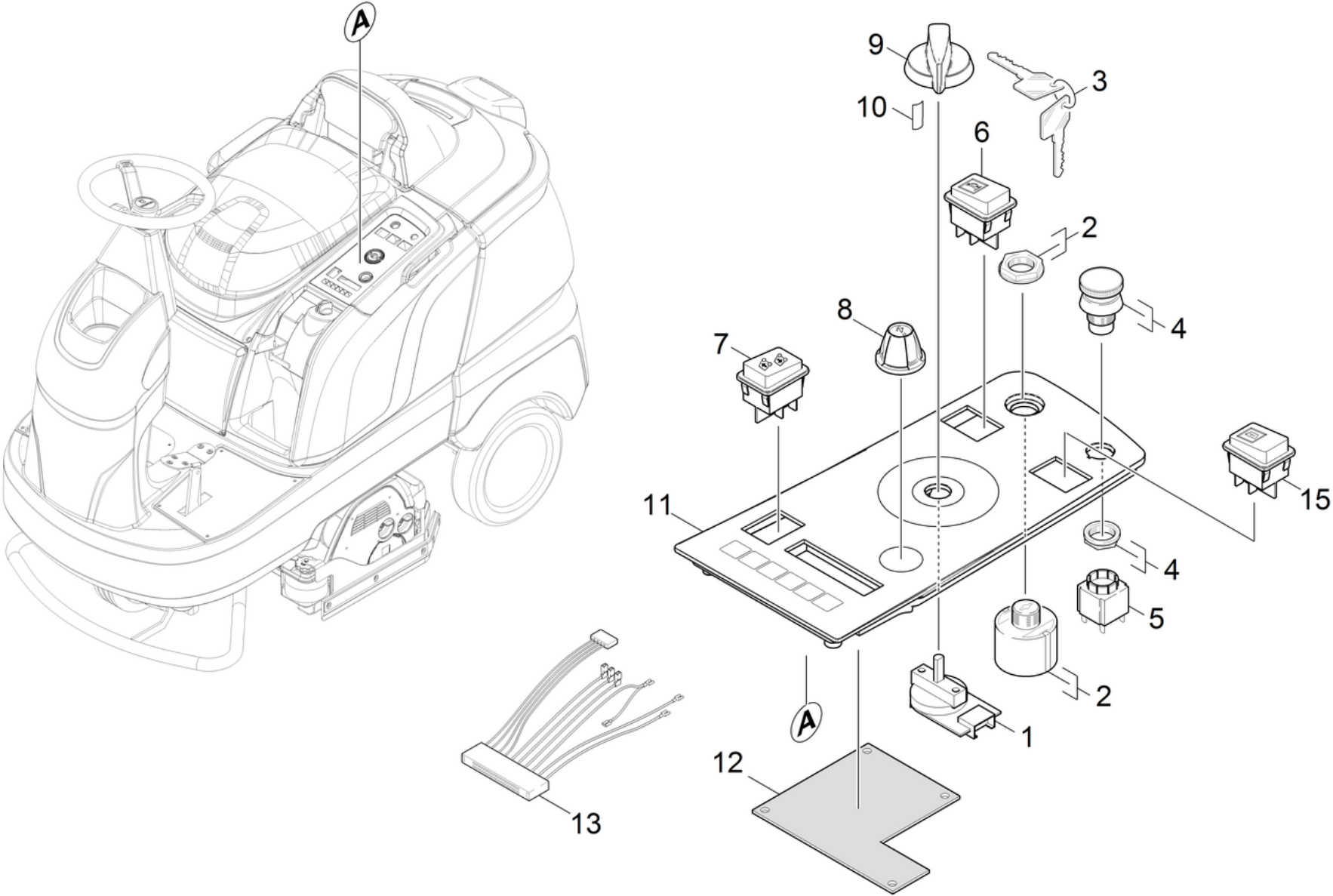

## 70 Bedienpult

POS	Artikelnr.	Beschreibung	Anzahl	Einheit
1	2.630-001.0	Schalter Programmwahl	1.000	ST
2	6.630-106.0	Schluesselschalter	1.000	ST
3	6.600-210.0	Schluessel nur fuer Ersatz	1.000	ST
4	6.600-344.0	Taster Not-Aus	1.000	ST
5	6.600-114.0	Schalter	1.000	ST
6	6.632-475.0	Taster 2-polig Hupe	1.000	ST
7	6.632-482.0	Schalter 2-polig Fahrtrichtung	1.000	ST
8	5.321-750.0	Griff Infopanel	1.000	ST
9	5.321-738.0	Griff Bedienkonzept	1.000	ST
10	6.313-014.0	Federungselement	1.000	ST
11	4.682-108.0	Bedienfeld mit Folie adv	1.000	ST
12	6.682-916.0	Platine adv.	1.000	ST
13	4.822-539.0	Kabelbaum Bedienfeld	1.000	ST
15	6.632-483.0	Schalter Chemie	1.000	ST

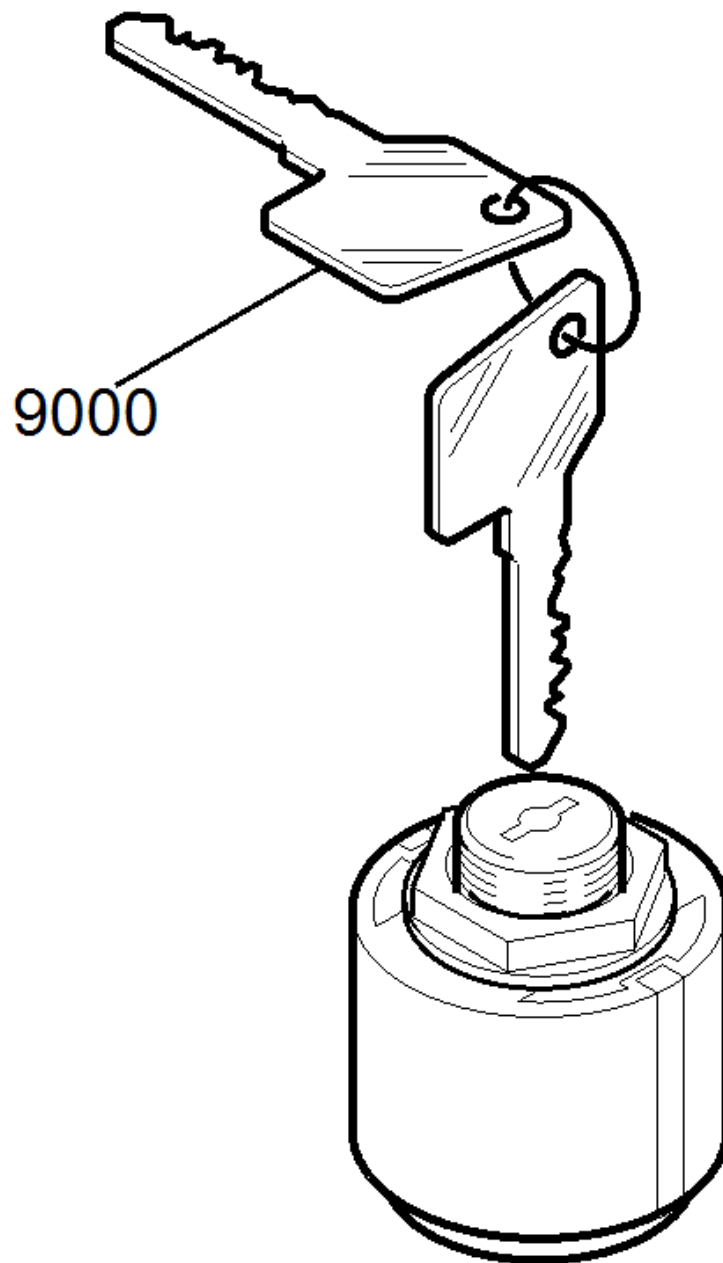

## 2 Schluesselschalter (6.630-106.0)

---

<b>POS</b>	<b>Artikelnr.</b>	<b>Beschreibung</b>	<b>Anzahl</b>	<b>Einheit</b>
9000	6.600-210.0	Schluessel nur fuer Ersatz	1.000	ST



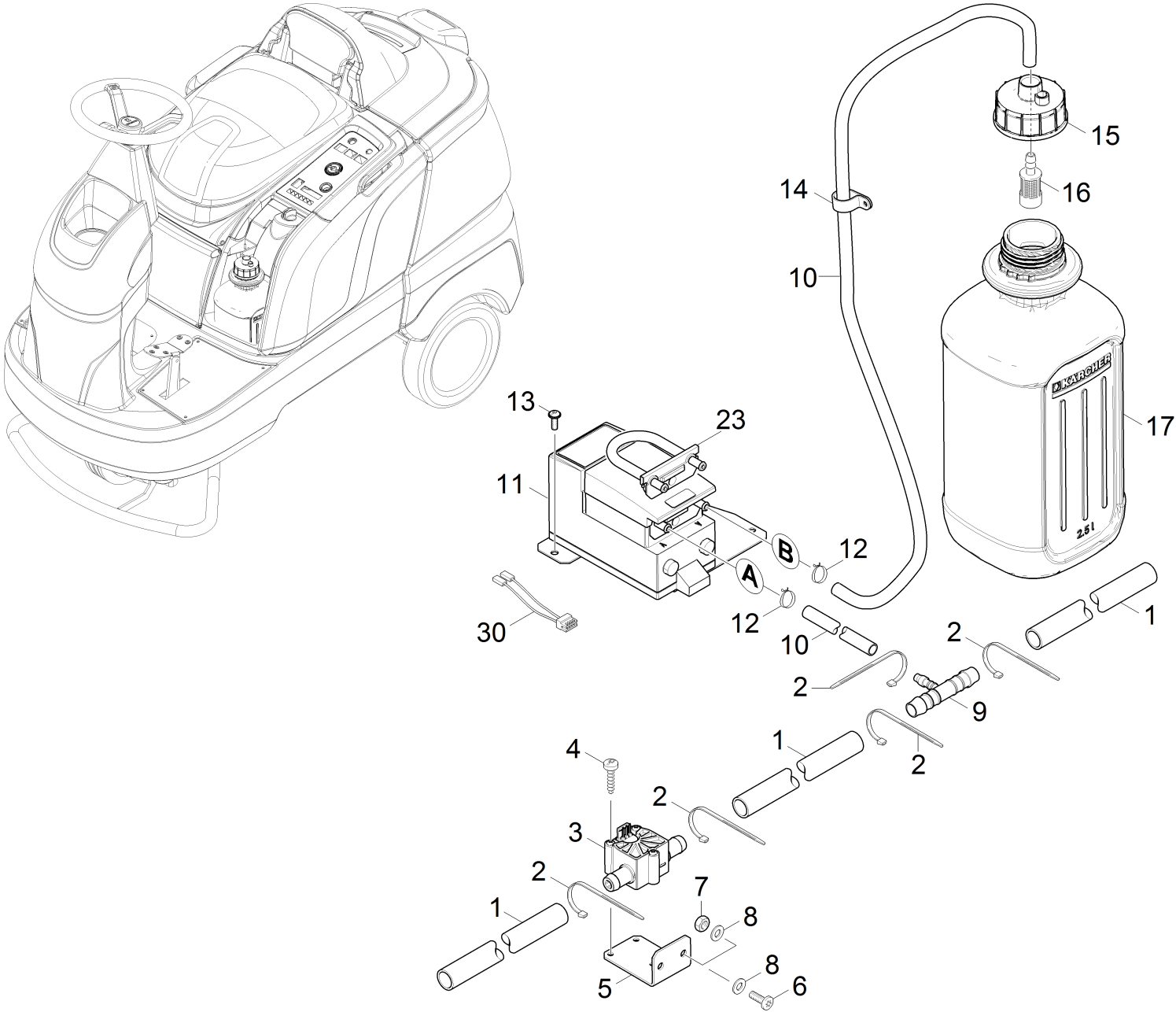

## 80 RM Dosierung

POS	Artikelnr.	Beschreibung	Anzahl	Einheit	Fußnotentext
1	6.388-248.0	Schlauch DN12,5	1.000	M	ALS METERWARE BESTELLEN
2	6.641-474.0	Kabelband 8-210	5.000	ST	
3	6.429-038.3	Durchflussmesser	1.000	ST	
4	7.303-106.0	Schraube 4x12 -10.9-R2R (IN6RD)	3.000	ST	
5	5.009-677.0	Halblech Durchflussmesser	1.000	ST	
6	7.306-182.0	Flachkopfschraube M5x16 -A2-70 ISO 14583	2.000	ST	
7	7.311-002.0	6kt-Mutter M5 -8-A2E ISO 4032	2.000	ST	
8	7.312-002.0	Scheibe 5-200HV-A3E ISO 7090	4.000	ST	
9	6.395-188.0	T-Stueck 12-6-12	1.000	ST	
10	6.391-341.0	Schlauch Chemie DN 6	1.000	M	ALS METERWARE BESTELLEN
11	6.762-208.0	Dosierpumpe B 90 R	1.000	ST	
12	6.389-768.0	Schlauchschelle	2.000	ST	
13	7.303-107.0	Schraube 5x16 -10.9-P2R (K-In6Rd)	4.000	ST	
14	6.641-460.0	Kabelschelle	1.000	ST	
15	5.064-415.0	Deckel RM	1.000	ST	GELB
15	4.060-625.0	Deckel RM	1.000	ST	SCHWARZ
16	5.731-652.0	Filter mit Gewicht	1.000	ST	
17	6.394-491.0	Flasche PE 2,5 L	1.000	ZST	
23	5.443-556.0	Schlauch Dosierpumpe nur fuer Ersatz	1.000	ST	
30	4.822-560.0	Kabel Dose B 90 R	1.000	ST	