

Ersatzteilliste

(1.042-506.0) HT 650/36 Bp

Inhaltsverzeichnis

HT 650/36 Bp (1.042-506.0)	3
1 HT Battery 36 *INT	5
11 Tragegestell (6.373-071.0)	8

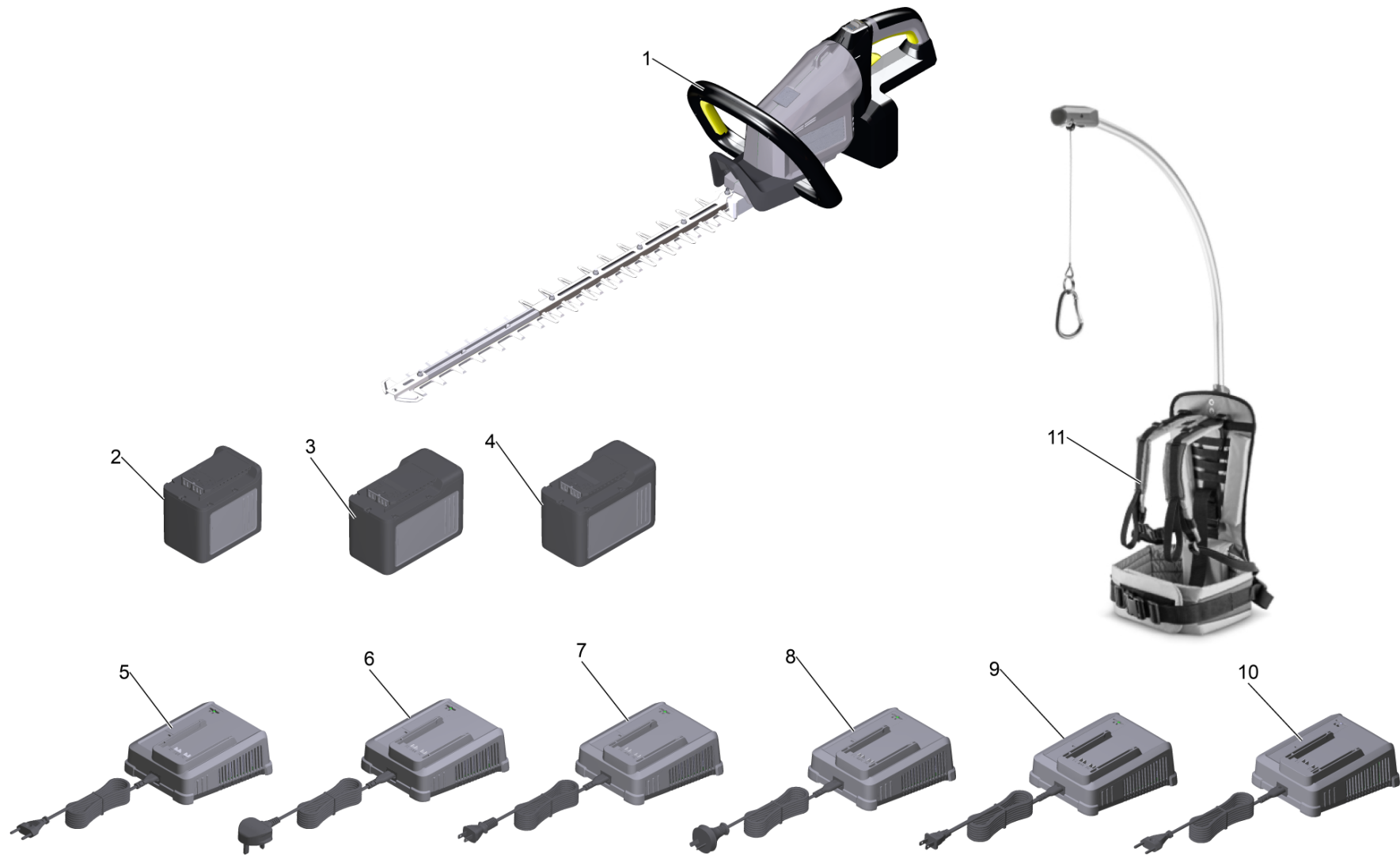

POS	Artikelnr.	Beschreibung	Anzahl	Einheit
1		HT Battery 36 *INT	1	ST
2	2.042-022.0	Battery Power+ 36/60 *INT	1	ST
3	2.445-043.0	Battery Power+ 36/75 *INT	1	ST
4	2.445-075.0	Battery Power+ 36/75 *CUL	1	ST
5	2.445-045.0	Ladegeraet Battery Power+ 36/60 *EU	1	ST
6	2.445-047.0	Ladegeraet Battery Power+ 36/60 *GB	1	ST
7	2.445-049.0	Ladegeraet Battery Power+ 36/60 *JP	1	ST
8	2.445-051.0	Ladegeraet Battery Power+ 36/60 *AU	1	ST
9	2.445-053.0	Ladegeraet Battery Power+ 36/60 *CUL	1	ST
10	2.445-054.0	Uni-Lader Battery Power+ 18-36/60 *EU	1	ST
11	6.373-071.0	Tragegestell	1	ST
12	2.445-070.0	Starter Kit Battery Power+ 36/75 *EU	1	ST
13	2.445-071.0	Starter Kit Battery Power+ 36/60 *EU	1	ST

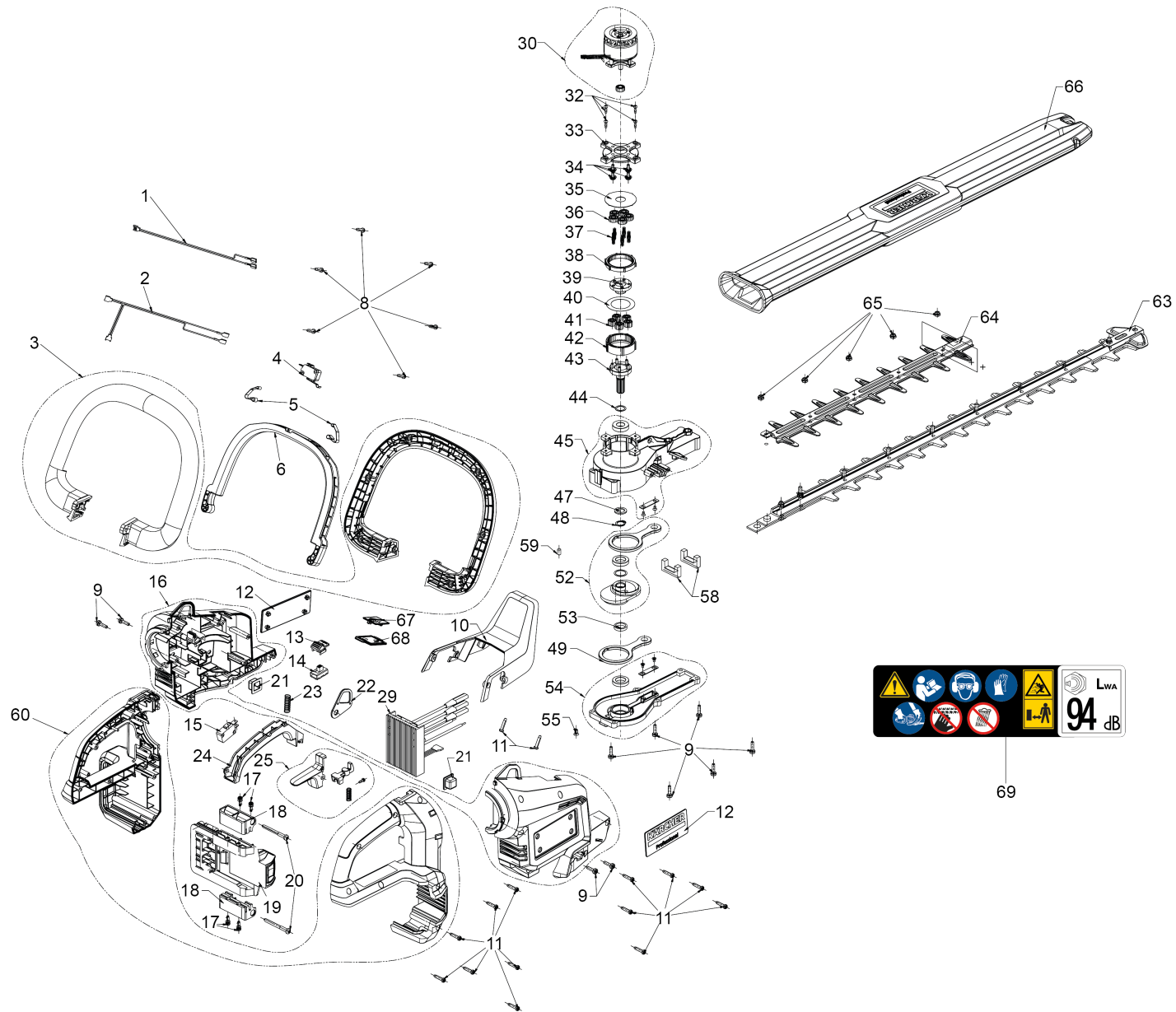

1 HT Battery 36 *INT

POS	Artikelnr.	Beschreibung	Anzahl	Einheit
1	6.445-142.0	Kabel Set Griff	1	ST
2	6.445-143.0	Kabel Set Griff	1	ST
3	6.445-144.0	Set Griff	1	ST
4	6.043-004.0	Mikroschalter HT 650/36 Bp	1	ST
5	6.444-767.0	Federplatte	2	ST
6	5.043-201.0	Abzug HT 650/36 Bp	1	ST
8	6.444-120.0	Schraube	6	ST
9	6.445-135.0	Schraube	10	ST
10	5.043-200.0	Schutz HT 650/36 Bp	1	ST
11	6.444-781.0	Schraube	15	ST
12	5.385-502.0	Schild Logo geclipst L Professional	2	ST
13	5.043-193.0	Regler Geschwindigkeit HT 650/36 Bp	1	ST
14	6.445-145.0	Schiebeschalter	1	ST
15	6.445-164.0	Mikroschalter	1	ST
16	6.445-146.0	Set Motorgehaeuse	1	ST
17	6.445-136.0	Schraube	4	ST
18	5.043-203.0	Adapter Batterie HT 650/36 Bp	2	ST
19	6.445-147.0	Set Aufnahme Batterie	1	ST
20	6.445-137.0	Schraube	2	ST
21	6.445-148.0	Gummi Halterung	2	ST
22	5.043-202.0	Stempel Einsatz HT 650/36 Bp	1	ST
23	6.444-776.0	Feder	1	ST
24	5.043-192.0	Taste HT 650/36 Bp	1	ST
25	6.445-149.0	Set Abzug	1	ST
29	6.445-150.0	Elektronik Set	1	ST
30	6.445-165.0	Set Motor	1	ST
32	6.445-138.0	Schraube	4	ST
33	6.445-151.0	Motorhalter	1	ST
34	6.444-954.0	Schraube M4x8.5	4	ST
35	6.445-166.0	Unterlegscheibe spezial	1	ST
36	6.445-167.0	Getriebe Planeten	5	ST
37	6.445-168.0	Getriebe	5	ST
38	6.445-169.0	Ring Getriebe	1	ST

1 HT Battery 36 *INT

POS	Artikelnr.	Beschreibung	Anzahl	Einheit
39	6.445-170.0	Fuehrung Getriebe	1	ST
40	6.445-171.0	Unterlegscheibe spezial	1	ST
41	6.445-172.0	Getriebe	5	ST
42	6.445-173.0	Ring Getriebe	1	ST
43	6.445-174.0	Welle	1	ST
44	6.445-175.0	Unterlegscheibe 12.1x16x0.5	1	ST
45	6.445-176.0	Gehaeuse Getriebe	1	ST
47	6.444-586.0	Unterlegscheibe	1	ST
48	6.445-177.0	Sicherungsring	1	ST
49	5.043-206.0	Pleuel HT 650/36 Bp	1	ST
52	6.445-178.0	Set Nocken	1	ST
53	6.445-179.0	Buchse 19x15.1x3.7	1	ST
54	6.445-180.0	Set Getriebegehaeuse	1	ST
55	6.445-139.0	Schraube M4x6	1	ST
58	6.445-152.0	Filz Dichtung	2	ST
59	6.445-153.0	Gummi Stopper	1	ST
60	6.445-154.0	Gehaeuse Set	1	ST
63	5.043-191.0	Klinge HT 650/36 Bp	1	ST
64	5.043-190.0	Klinge Schutz HT 650/36 Bp	1	ST
65	6.444-826.0	Mutter	5	ST
66	5.043-211.0	Kettenschutz HT 650/36 Bp	1	ST
67	5.385-506.0	Schild Signet geclipst M Professional	1	ST
68	5.042-207.0	Halterung Signet M geklipst	1	ST
69	5.385-174.0	Aufkleber Hinweis HT 650/36 Bp	1	ST

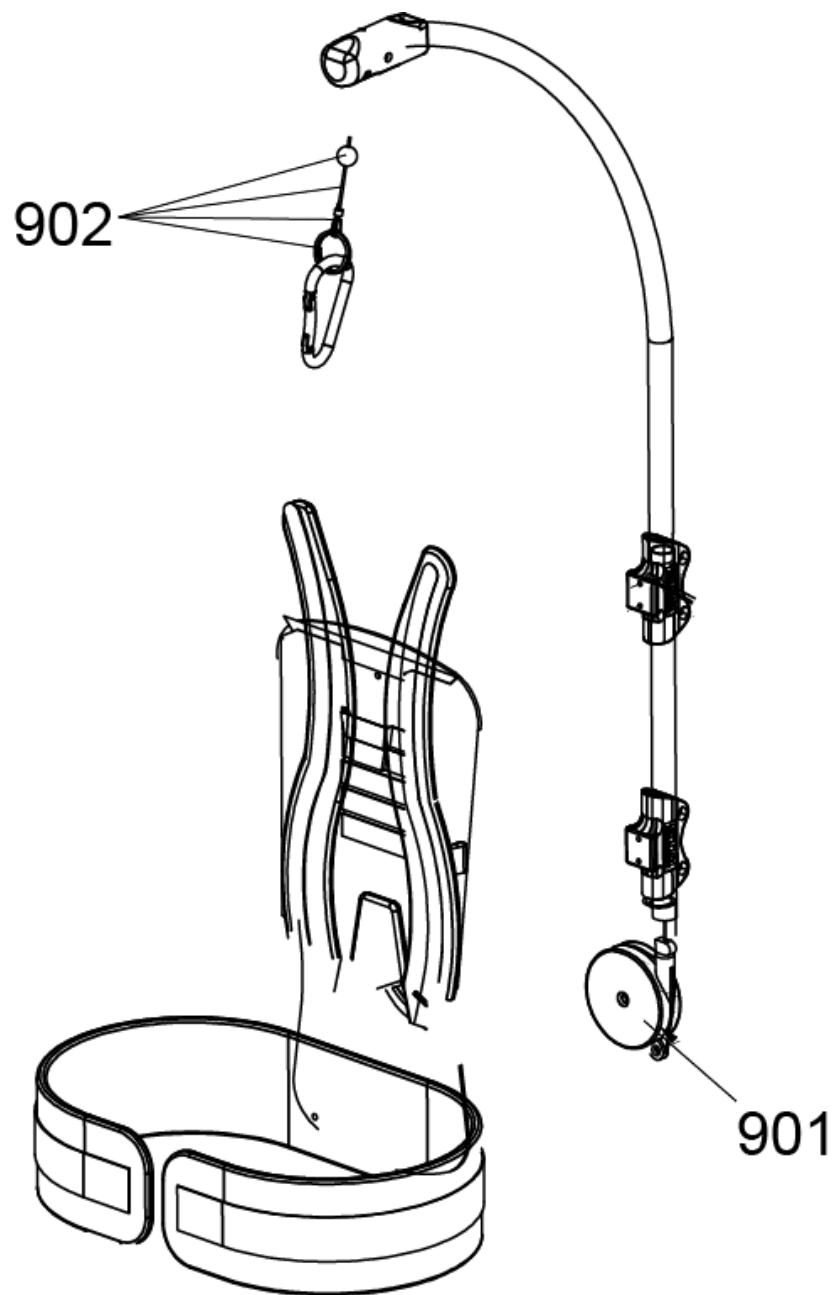

11 Tragegestell (6.373-071.0)

POS	Artikelnr.	Beschreibung	Anzahl	Einheit
901	6.100-560.0	Balancer	1	ST
902	6.100-561.0	Kabelsatz	1	ST