

## **Ersatzteilliste**

(1.042-512.0) MT CS 250/36

## Inhaltsverzeichnis

---

MT CS 250/36 (1.042-512.0)	3
1 MT CS Battery 36 *INT	5

---

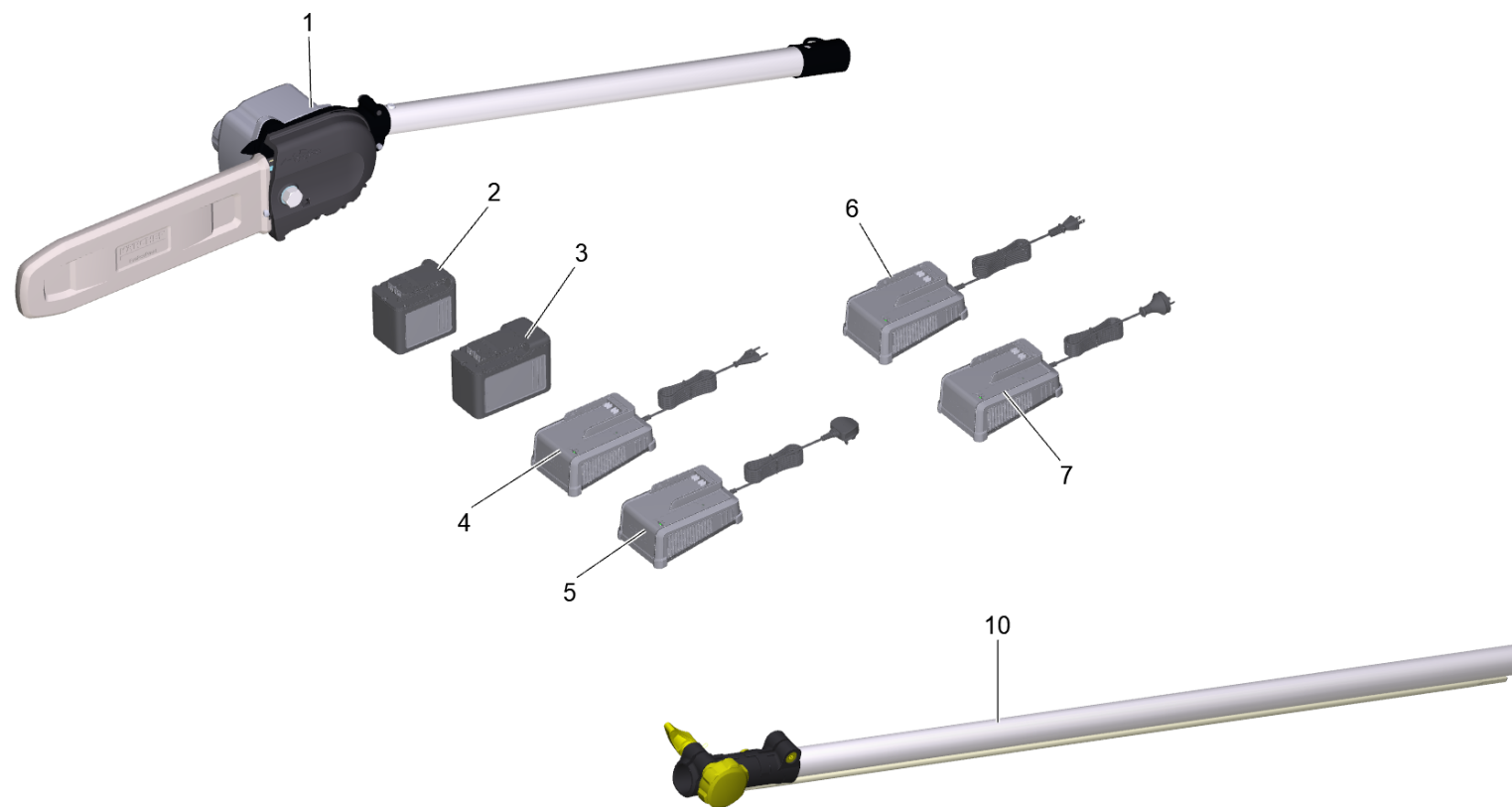

MT CS 250/36 (1.042-512.0)

POS	Artikelnr.	Beschreibung	Anzahl	Einheit
1		MT CS Battery 36 *INT	1	ST
2	2.042-022.0	Battery Power+ 36/60 DW *INT	1	ST
3	2.445-043.0	Battery Power+ 36/75 DW *INT	1	ST
4	2.445-045.0	Schnellladegeraet Battery Power+ 36/60 *EU	1	ST
5	2.445-047.0	Schnellladegeraet Battery Power+ 36/60 *GB	1	ST
6	2.445-049.0	Schnellladegeraet Battery Power+ 36/60 *JP	1	ST
7	2.445-051.0	Schnellladegeraet Battery Power+ 36/60 *AU	1	ST
8	2.445-070.0	Starter Kit Battery Power+ 36/75	1	ST
9	2.445-071.0	Starter Kit Battery Power+ 36/60	1	ST
10	2.042-031.0	MT EXT 100	1	ST

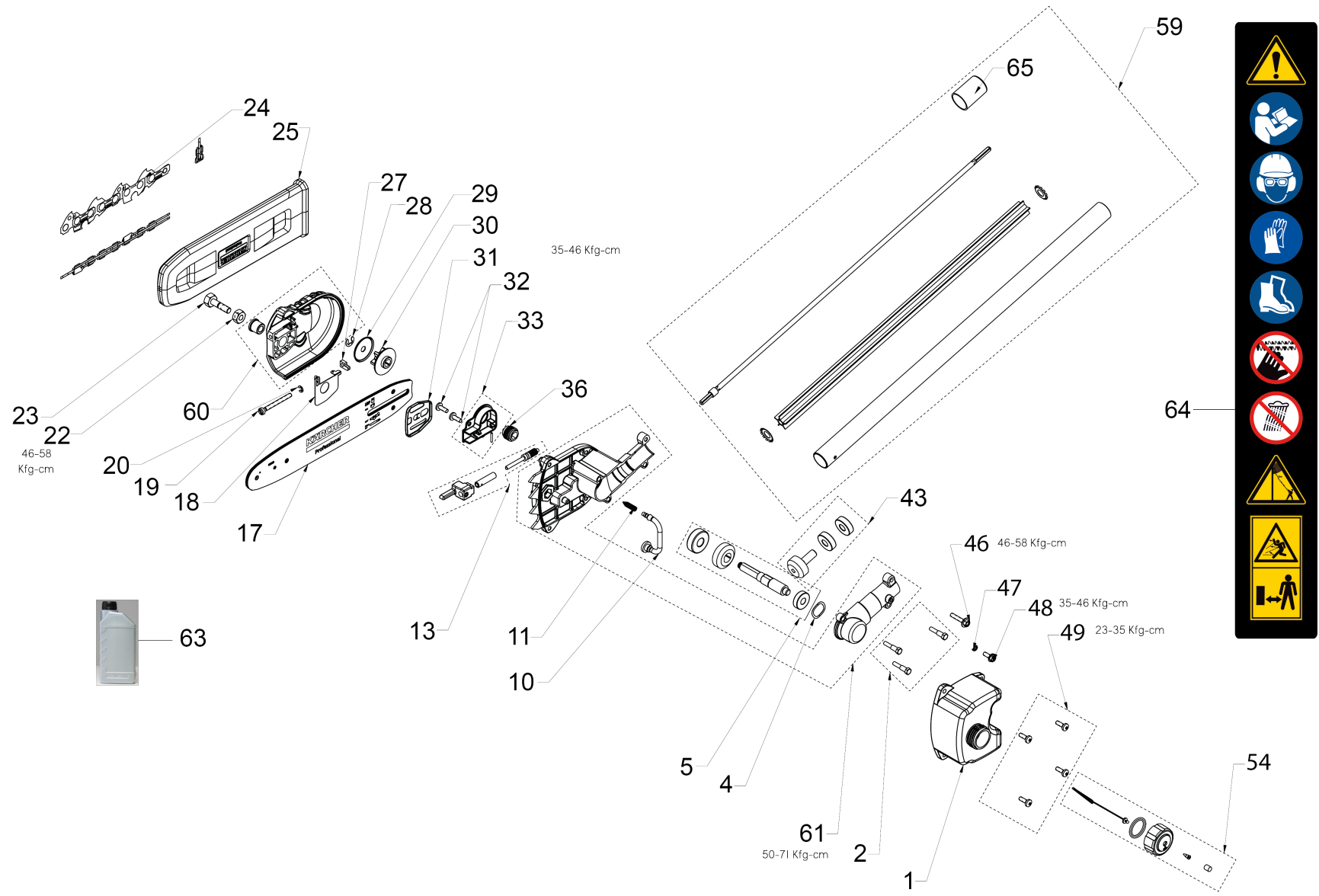

## 1 MT CS Battery 36 \*INT

POS	Artikelnr.	Beschreibung	Anzahl	Einheit
1	6.444-667.0	Oeltank	1	ST
2	6.444-668.0	Schraube	3	ST
4	6.444-669.0	Unterlegscheibe	1	ST
5	6.444-670.0	Welle Ausgang	1	ST
10	6.444-671.0	Rohrleitung Oel	1	ST
11	6.444-672.0	Feder	1	ST
13	6.444-673.0	Set Oelpumpe	1	ST
17	2.042-021.0	Fuehrungsschiene Kettensaege 25cm	1	ST
18	6.444-676.0	Platte	1	ST
19	6.444-677.0	Schraube	1	ST
20	6.444-678.0	Sicherungsring	1	ST
22	6.444-679.0	Mutter M8	1	ST
23	6.444-680.0	Schraube	1	ST
24	2.042-020.0	Saegekette "Oregon" 25cm	1	ST
25	5.042-234.0	Kettenschutz MT CS 250/36	1	ST
27	6.444-675.0	Fuehrungsklotz	1	ST
28	6.444-681.0	Sicherungsring	1	ST
29	6.444-682.0	Abdeckung	1	ST
30	6.444-683.0	Kettenrad	1	ST
31	6.444-684.0	Abdeckplatte	1	ST
32	6.444-685.0	Schraube	2	ST
33	6.444-686.0	Gehaeuse Oelpumpe	1	ST
36	6.444-687.0	Schneckengetriebe	1	ST
43	6.444-688.0	Zahnradwelle	1	ST
46	6.444-689.0	Schraube	1	ST
47	6.444-690.0	Federscheibe	1	ST
48	6.444-691.0	Schraube	1	ST
49	6.444-692.0	Schraube	4	ST
54	6.444-693.0	Deckel Oel kpl.	1	ST
59	6.444-674.0	Set Antriebswelle	1	ST
60	6.444-694.0	Set Abdeckung	1	ST
61	6.444-695.0	Set Abdeckung Getriebe	1	ST
63	6.990-531.0	Bio Saegeketteneoel Planto Tac 68	1	ST

1 MT CS Battery 36 \*INT

---

<b>POS</b>	<b>Artikelnr.</b>	<b>Beschreibung</b>	<b>Anzahl</b>	<b>Einheit</b>
64	5.385-160.0	Aufkleber Hinweis Multi-Tool Chain Saw	1	ST
65	6.444-760.0	Abdeckkappe	1	ST