

## **Ersatzteilliste**

(1.042-513.0) MT HT 550/36

## Inhaltsverzeichnis

---

MT HT 550/36 (1.042-513.0)	3
1 MT Battery 36 *INT	5

---

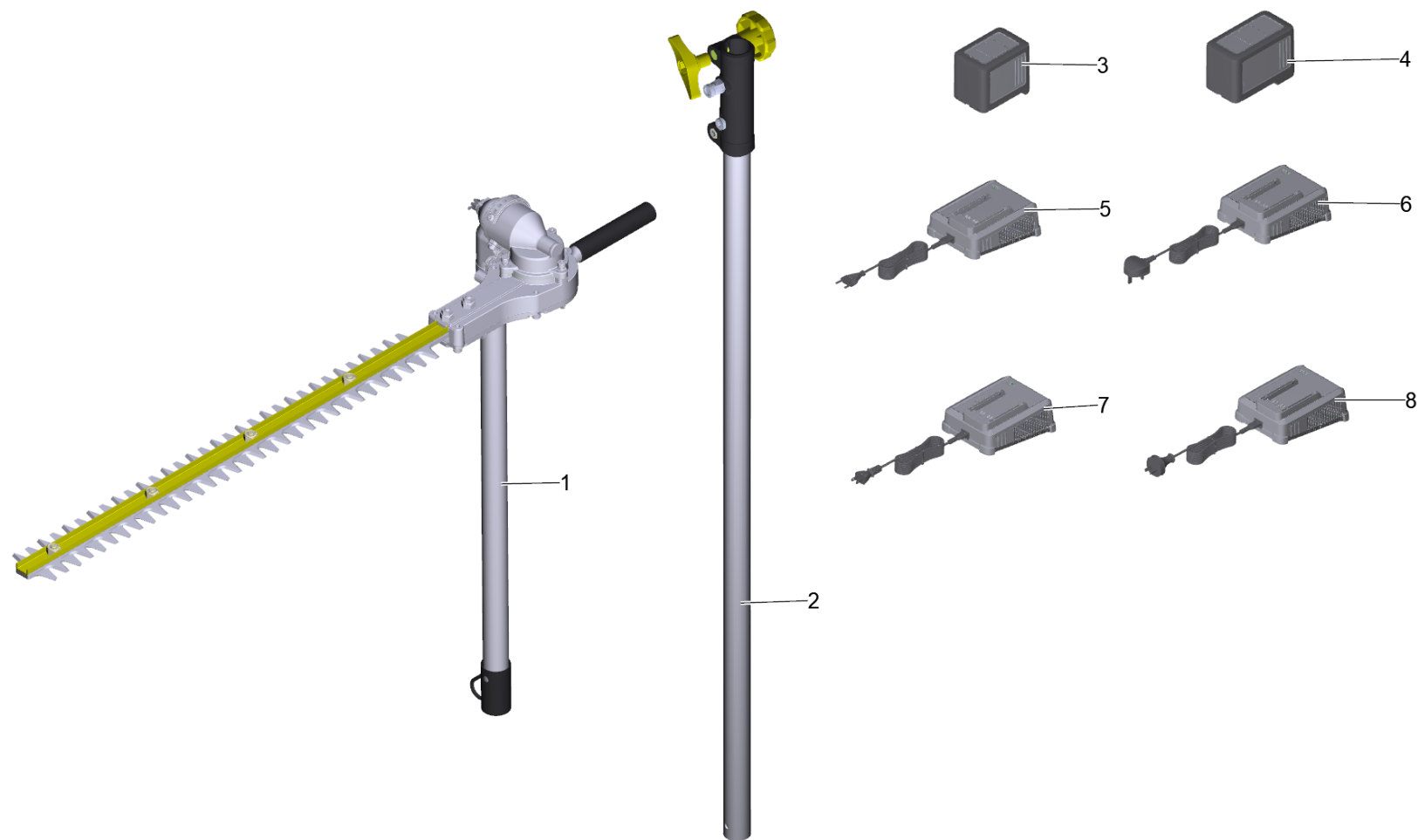

MT HT 550/36 (1.042-513.0)

POS	Artikelnr.	Beschreibung	Anzahl	Einheit
1		MT Battery 36 *INT	1	ST
2	2.042-031.0	MT EXT 100	1	ST
3	2.042-022.0	Battery Power+ 36/60 DW *INT	1	ST
4	2.445-043.0	Battery Power+ 36/75 DW *INT	1	ST
5	2.445-045.0	Schnellladegeraet Battery Power+ 36/60 *EU	1	ST
6	2.445-047.0	Schnellladegeraet Battery Power+ 36/60 *GB	1	ST
7	2.445-049.0	Schnellladegeraet Battery Power+ 36/60 *JP	1	ST
8	2.445-051.0	Schnellladegeraet Battery Power+ 36/60 *AU	1	ST
9	2.445-070.0	Starter Kit Battery Power+ 36/75	1	ST
10	2.445-071.0	Starter Kit Battery Power+ 36/60	1	ST
11	2.445-072.0	Starter Kit Battery Power+ 18/30	1	ST

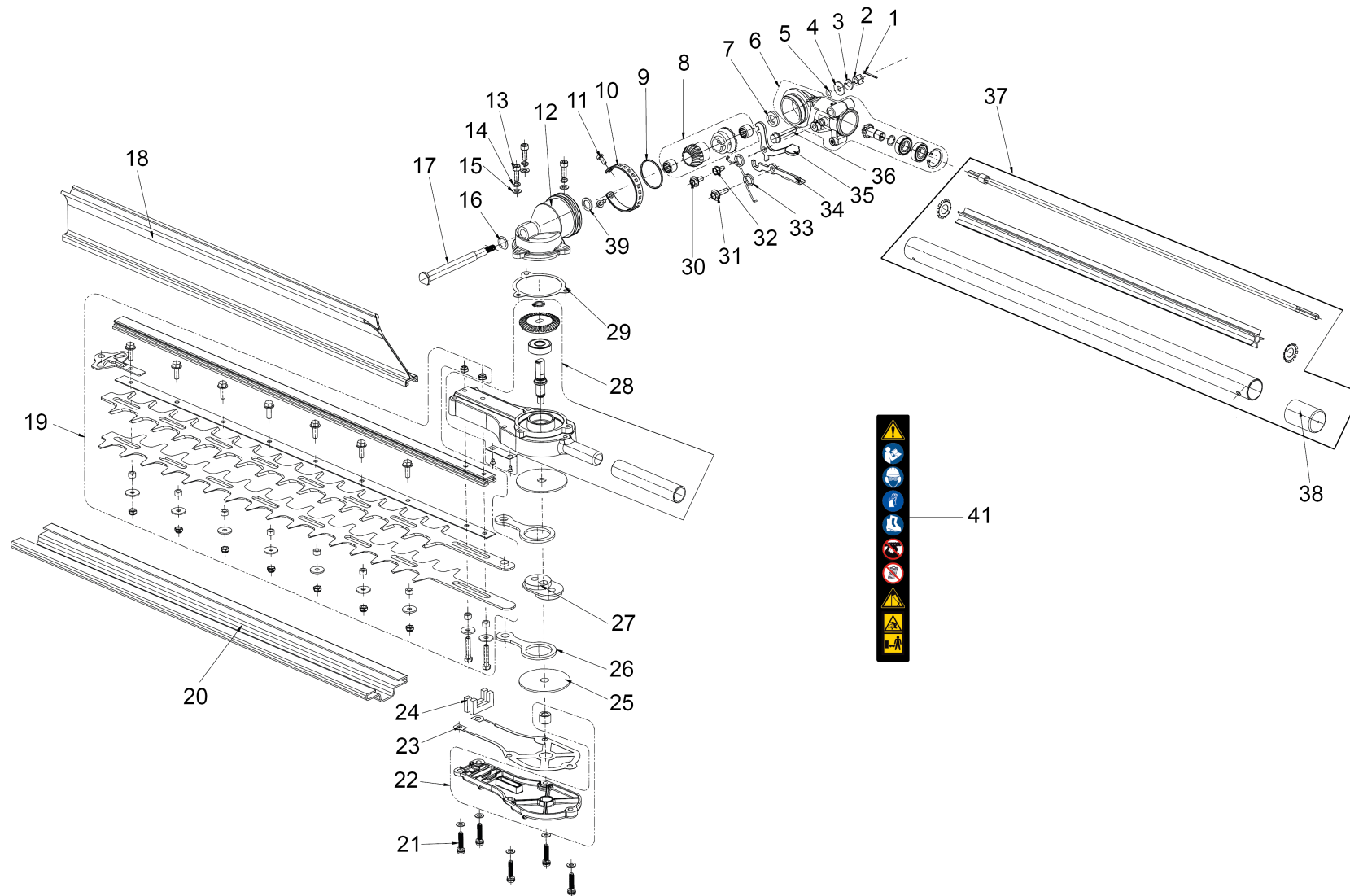

## 1 MT Battery 36 \*INT

POS	Artikelnr.	Beschreibung	Anzahl	Einheit
1	6.444-719.0	Splint	1	ST
2	6.444-720.0	Mutter	1	ST
3	6.444-721.0	Federscheibe	1	ST
4	6.444-722.0	Unterlegscheibe	1	ST
5	6.444-723.0	O-Ring	1	ST
6	6.444-724.0	Set Getriebe	1	ST
7	6.444-725.0	Unterlegscheibe	1	ST
8	6.444-726.0	Set Zahnrad	1	ST
9	6.444-727.0	O-Ring	1	ST
10	6.444-728.0	Band Arretierung	1	ST
11	6.444-729.0	Schraube	2	ST
12	6.444-730.0	Gehaeuse Getriebe	1	ST
13	6.444-731.0	Schraube	3	ST
14	6.444-690.0	Federscheibe	3	ST
15	6.444-732.0	Unterlegscheibe	8	ST
16	6.444-733.0	O-Ring	1	ST
17	6.444-734.0	Ausgangswelle	1	ST
18	6.444-735.0	Schnittgutkehrer	1	ST
19	6.444-736.0	Messer	1	ST
20	5.042-230.0	Schutz Klinge MT HT 550/36	1	ST
21	6.444-737.0	Schraube M5 x 0,8	5	ST
22	6.444-738.0	Getriebe Box unten	1	ST
23	6.444-739.0	Dichtung	1	ST
24	6.444-741.0	Filz Dichtung	2	ST
25	6.444-742.0	Unterlegscheibe	2	ST
26	6.444-743.0	Pleuelstange	2	ST
27	6.444-744.0	Nocken doppelt	1	ST
28	6.444-746.0	Getriebe Box oben	1	ST
29	6.444-747.0	Dichtung	1	ST
30	6.444-748.0	Schraube	1	ST
31	6.444-749.0	Schraube	1	ST
32	6.444-750.0	Schraube	1	ST
33	6.444-751.0	Feder	1	ST

## 1 MT Battery 36 \*INT

---

<b>POS</b>	<b>Artikelnr.</b>	<b>Beschreibung</b>	<b>Anzahl</b>	<b>Einheit</b>
34	6.444-752.0	Sicherheitsverschluss	1	ST
35	6.444-753.0	Arretierung Verriegelung	1	ST
36	6.444-754.0	Schraube	1	ST
37	6.444-755.0	Antriebswelle	1	ST
38	6.444-760.0	Abdeckkappe	1	ST
39	6.444-756.0	Unterlegscheibe	1	ST
41	5.385-160.0	Aufkleber Hinweis Multi-Tool Chain Saw	1	ST